



LIGHTING AND WARNING PRODUCTS 2024

LIGHT-YEARS AHEAD™



TRITON SIGNAL USA

1025 N. Lombard Rd., Lombard Illinois 60148
1-877-874-3744 • www.triton-signal.com



A WARM WELCOME TO TRITON SIGNAL USA'S 2024 PRODUCTS CATALOG

Triton Signal USA is currently celebrating its 15th year of business, we are grateful for the continued, loyal support of our customers.

Our company's mantra is "Rapid development and introduction of industry-leading products, at a fair price", and last year was no exception, as we developed a host of new products, spurring the need for this latest products catalog.

A new development in vehicle warning lamps, is the use of green and amber/green strobes, these are being adopted by several states as more visible than amber and are being led by snowplow and salt truck equipment. In line with our mantra of "Rapid development of industry-leading products, at a fair price", we have recently added around a dozen green or amber/green strobe products.

Triton Signal USA is proud to be a market leader in our field, we are intensely focused on supplying the highest quality, most rugged and durable products, with unique and patented features. In a crowded market, with a myriad of product choices, we are confident you'll find that our world-class products and service stand out from the rest.

All of us on the Triton team appreciate your interest, continued patronage and support.

Sincerely, Mark T. Coward, President.

INDEX OF CONTENTS

LED WORK LAMPS	1
DEERE COMPACT TRACTOR AFTERMARKET DOT LAMPS	11
DEERE “GATOR” LAMPS UPFITTING KITS	12
DRIVING LIGHT-BARS	13
MOUNTING BRACKETS AND WIRING HARNESSSES.....	14
REMOTE CONTROLLED SEARCHLIGHTS	16
SNOW-PLOW AND SALT TRUCK LAMPS	17
DOT LED BULBS FOR HEADLAMPS AND GENERAL USE	20
DOT SEALED BEAM RETROFIT HEADLAMPS	22
FORKLIFT PRODUCTS (LAMPS, LASERS AND CAMERAS)	23
AMBER WARNING LAMPS AND SURFACE STROBES	30
AMBER WARNING LIGHT-BARS	49
FULL-SIZE AMBER WARNING LIGHT-BARS	55
DOT SIGNAL AND MARKER LAMPS	59
CAMERA SYSTEMS – WIRED AND WIRELESS	62
INTERIOR AND CARGO LAMPS	73
ROCK-LIGHTS, WHEEL-WELL LIGHTING	78
PORTABLE RECHARGEABLE PRODUCTS	79
VAN AND TRUCK UPFITTING LED STRIPS	102
BACK-UP ALARMS	105
CONTACT US	108

HIGH-INTENSITY HEAVY DUTY WORK LAMPS

Model #	Applications	Watts	Lumens	Pattern	Shape	Voltage	Page
TLL-9	ATV/Small Truck/ Lawnmower	9	500	Flood	Oval	10-32V	3
TLL-9V	Forklift	9	500	Flood	Oval	10-60V	3
TLL-11	Motorcycle Van/Forklift/ATV	12	800	Spot	Rectangle	10-32V	3
TLL-12	Van/Forklift/ ATV	24	1500	Flood	Square	10-32V	3
TLL-14	Small Truck/ Van/Forklift/ ATV	12	900	Flood	Square	10-32V	3
TLL-15V	Forklift	15	950	Flood	Square	10-60V	23
TLL-16S (Square)	Utility Truck/ SUV/Van	18	1260	Flood	Square	10-32V	8
TLL-16R (Round)	Utility Truck/ SUV/Van	18	1260	Flood	Round	10-32V	3
TLL-17R (Round)	Dozer/Heavy Construction/ Utility Truck	27	1660	Flood	Round	10-32V	3
TLL-17S (Square)	Dozer/Heavy Construction/ Utility Truck	27	1660	Flood	Square	10-32V	3
TLL-18F	Dozer/Heavy Utility Truck	18	1260	Flood	Round	10-32V	3
TLL-19	Dozer/Heavy Construction/ Utility Truck	45	3100	Flood	Rectangle	10-32V	4

All Triton Work Lamps Carry a 10-Year Warranty

High Intensity Heavy Duty Work Lamps

Model #	Applications	Watts	Lumens	Pattern	Shape	Voltage	Page
TLL-20 TLL-20C (Flood/Spot)	Utility Trucks/ Heavy Construction	108	7500	Flood Flood/Spot	Rectangle	10-32V	4
TLL-21	Forklift Reverse Blue Lamp	10	750	Blue Spot	Oval	10-60V	23
TLL-22R	Forklift Safety Clearance	6	180	Red Line	Oval	10-80V	24
TLL-23	Work Lamp/ Driving Lamp	25	2250	Flood	Square	10-32V	4
TLL-24R	Forklift Safety Clearance	10	100	Red Halo	Oval	10-80V	24
TLL-25V	Forklift Driving Lamp	25	2100	Flood	Rectangle	10-60V	24
TLL-27YW	Snow Plows/ Salt Spreaders	27	2100	Yellow White	Square	10-32V	19
TLL-30	Dozer/Heavy Utility Truck	30	3000	Flood	HEX	10-32V	4
TLL-39	Dozer/Heavy Construction/ AG Machines	39	3900	Flood	Oval	10-32V	4
TLL-40H HEATED LENS	Snow Plows/ Salt Spreaders	40	4100	Flood	Square	10-32V	19
TLL-48	AG Machines	48	3200	80 Degrees	Square	10-32V	8
TLL-50	AG Machines/ Mining	50	3170	80 Degrees	Rectangle	10-32V	4
TLL-54	AG Machines/ Mining Dozer/Heavy	54	3960	80 Degrees	Rectangle	10-32V	8
TLL-65	Construction/ AG Machines/ Mining	65	4900	Flood	Oval	10-32V	7
TLL-70	AG Machines/ Mining/Heavy Construction	70	6300	Combo	Round	10-32V	7
TLL-70S	AG Machines/ Mining/Heavy Construction	70	6000	80 Degrees	Square	10-32V	7
TLL-108	AG Machines/ Mining	108	7920	80 Degrees	Rectangle	10-32V	8
TLL-120SD	AG Machines/ Mining	120	10200	Flood	Square	10-32V	5
TLL-130	AG Machines/ Mining	130	10140	80 Degrees	Round	10-32V	7

All Triton Work Lamps Carry a 10-Year Warranty



TLL-9V

- Super-white, 4x3 Watt High-Intensity CREE LEDs
- 3.5" x 3" x 2" Oval Aluminum Sealed Housing
- 10-60V
- Polycarbonate Lens
- 9 Watts Flood
- 500 Lumens



TLL-11

- Super-white, 4x3 Watt High-Intensity CREE LEDs
- 2.75" Square Cast Aluminum Sealed Housing
- 12-24V DC
- Polycarbonate Lens
- 12 Watts Flood
- 800 Lumens



TLL-12

- Super-white, 4x6 Watt High-Intensity CREE LEDs
- 3" x 3" x 1.5" Cast Aluminum Sealed Housing
- 10-32V
- Polycarbonate Lens
- 24 Watts Flood
- 1500 Lumens



TLL-14

- Super-white, 4x3 Watt High-Intensity CREE LEDs
- 2.5" Square Cast Aluminum Sealed Housing
- 10-32V DC
- Polycarbonate Lens
- 12 Watts Flood
- 900 Lumens



TLL-15V

- White, 5x3 Watt High-Intensity LEDs
- 4" Square Cast Aluminum Sealed Housing
- 10-60V DC
- Polycarbonate Lens
- 15 Watts Flood
- 950 Lumens



TLL-16S

- White, 6x3 Watt High-Intensity CREE LEDs
- 4" Square Cast Aluminum Sealed Housing
- 10-32V DC
- Polycarbonate Lens
- 18 Watts Flood
- 1260 Lumens



TLL-16R

- White, 6x3 Watt High-Intensity CREE LEDs
- 4" Round Cast Aluminum Sealed Housing
- 10-32V DC
- Polycarbonate Lens
- 18 Watts Flood
- 1260 Lumens



TLL-17R

- White, 9x3 Watt High-Intensity CREE LEDs
- 4" Round Cast Aluminum Sealed Housing
- 10-32V DC
- Polycarbonate Lens
- 27 Watts Flood
- 1660 Lumens



TLL-17S

- White, 9x3 Watt High-Intensity CREE LEDs
- 4" Square (R) Cast Aluminum Sealed Housing
- 10-32V DC
- Polycarbonate Lens
- 27 Watts Flood
- 1660 Lumens



TLL-18FF

- White, 6x3 Watt High-Intensity CREE LEDs
- 5" Round Cast Aluminum Sealed Housing
- 10-32V DC
- Polycarbonate Lens
- 18 Watts Flood
- 1260 Lumens



TLL-19

- Super-white, 15x3 Watt High-Intensity CREE LEDs
- 6"x4" Rectangle Cast Aluminum Sealed Housing
- 10-32V DC
- Polycarbonate Lens
- 45 Watts Flood
- 3100 Lumens



TLL-20C

- Super-white, 36x3 Watt High-Intensity CREE LEDs
- 9" x 5" Rectangle Cast Aluminum Sealed Housing
- 10-32V DC
- Polycarbonate Lens
- 108 Watts Flood
- 7500 Lumens



TLL-23

- 5x5 Watt High-Intensity CREE LEDs
- 5.5"x1.75"x3" Rectangle Cast Aluminum Sealed Housing
- 10-32V DC
- 2250 Lumens
- 180 Degree Mount Horizontal to Vertical



TLL-25V

- White, 5x5 Watt High-Intensity LEDs
- 4" Square CREE Cast Aluminum Sealed Housing
- 10-60V DC
- Polycarbonate Lens
- 25 Watts Flood
- 2100 Lumens



TLL-30

- White High-Intensity LEDs
- 4.5"x2"x5.5" Flood CREE Cast Aluminum Sealed Housing
- 10-32V
- Polycarbonate Lens
- 30 Watts Flood
- 3000 Lumens



TLL-39

- White, 13x3 Watt High-Intensity LEDs
- 5.5"x4"x3" Cast Aluminum Sealed Housing
- 10-32V DC
- Polycarbonate Lens
- 39 Watts Flood
- 3900 Lumens



TLL-50

- White, 13x5 Watt High-Intensity LEDs
- 7"x5"x3.5" Oval CREE Cast Aluminum Sealed Housing
- 10-32V DC
- Polycarbonate Lens
- 50 Watts Flood
- 4900 Lumens



TLL-70S

- White, 10x7 Watts High-Intensity CREE LEDs
- 7"x5"x3.5" Flood CREE Aluminum Sealed Cast
- 10-32V DC
- Polycarbonate Lens
- 70 Watts Flood
- 6000 Lumens



TLL-120-SD SUPER-DUTY 12,000 LUMENS WORK LAMP

FOR INTENSELY RUGGED
APPLICATIONS

- * MINING
- * CONSTRUCTION
- * AGRICULTURE



12,000
EFFECTIVE
LUMENS

12000 Lumens Super Duty Work Light

- Power : 120W 12pcs 10W CREE Leds
- Lumen: 12000LM
- Voltage: 10-30V DC
- Beam Pattern: Flood
- Dimensions: 7.5" x 5.5" x 6.5" (W/D/H)
- Color Temp : 6500K
- Waterproof: IP68
- Warranty 3 years
- Material: Diecast aluminum housing; PC Lens



TLL-400 SIDEKICK™ & TLL-700 SIDEWINDER™ 130 DEGREE DISPERSION WORKLAMPS



**TLL-400 SIDEKICK
WHITE 130 DEGREE WORKLAMP**



WIDE 130 DEGREE BEAM

- WIDE-BEAM 40 WATTS WORKLAMP
- RUGGED DIECAST ALUMINUM HOUSING
- POLYCARBONATE (PC) WRAPPED LENS
- STAINLESS STEEL BRACKET
- SEALED IP67 DESIGN
- 4,000 LUMENS FLOOD BEAM

TLL-700 SIDEWINDER MODELS

**TLL-700FA: WHITE WORKLAMP AND
AMBER WARNING STROBE**

**TLL-700FR: WHITE WORKLAMP AND
RED WARNING STROBE**

- 70 WATTS WORKLAMP
- 30 WATTS AMBER WARNING STROBE
- RUGGED DIECAST ALUMINUM HOUSING
- POLYCARBONATE (PC) WRAPPED LENS
- STAINLESS STEEL BRACKET
- SEALED IP67 DESIGN
- 3,450 LUMENS FLOOD BEAM

TRITON 3 YEAR LIMITED WARRANTY



**TLL-700 SIDEWINDER
WHITE 90 DEGREE WORKLAMP
WITH AMBER OR RED STROBE**



HEAVY-DUTY LED WORK LAMPS FOR MINING, AG & CONSTRUCTION

COMMON FEATURES

Die Cast, Aluminum Alloy Body, Lexan Polycarbonate Lens, CE/E-mark Certified
9-36 Volts DC, 10-Year Warranty



TLL-70S

White, 14x5 Watts
High-Intensity CREE LEDs
Aluminum Sealed Square Cast
10-32V Polycarbonate Lens
70 Watts Flood
4000 Lumens
Waterproof IP68 Rating



TLL-65

White, 13x5 Watt
High-Intensity CREE LEDs
7"x5"x3" Oval Cast Aluminum Sealed Housing
10-32V
Polycarbonate Lens
65 Watts Flood
4900 Lumens



TLL-120-SD (SUPER-DUTY)

12x 10W CREE LEDs
IP68 Sealed Rating
Intensity: 12,000 Lumens
60 Degree Flood Beam
Dimensions: 6" x 7" x 5" H/W/D



TLL-130

13x10W CREE LEDs
IP68 Sealed Rating
Intensity: 10,140 Lumens
10/60 Degrees Spot/Flood Beam
Dimensions: 9" x 8" x 5-3/4" (H/W/D)



TLL-70

7x10W CREE LEDs
IP68 Sealed Rating
Intensity: 6,300 Lumens
10/60 Degrees Spot/Flood Beam
Dimensions: 7" x 6" x 3.5" (H/W/D)

All Triton Work Lamps Carry a 10-Year Warranty

WIDE-ANGLE LED WORK LAMPS FOR AGRICULTURAL MACHINERY



Agricultural Lighting

TLL-16S



- Dimensions: 4.5" x 3" x 2" (W/H/D)
- 6x3W LEDs (18 Watts)
- 12/24 Volts
- 80 Degrees AG-Flood Beam
- 1,260 Lumens

TLL-48



- Dimensions: 5.5" x 5" x 2" (W/H/D)
- 16 pcs 3W LEDs (48 Watts)
- 12/24 Volts
- 80 Degrees AG-Flood Beam
- 3,200 Lumens

TLL-54



- Dimensions: 7" x 3" x 1.5" (W/H/D)
- 18x3W LEDs (54 Watts)
- 12/24 Volts
- 80 Degrees AG-Flood Beam
- 3,960 Lumens

TLL-108



- Dimensions: 16" x 5" x 1-3/4" (W/H/D)
- 36 pcs 3W LEDs (108 Watts)
- 12/24 Volts
- 80 Degrees AG-Flood Beam
- 7,920 Lumens

All Triton Work Lamps Carry a 10-Year Warranty

SEAWOLF™

HEAVY-DUTY LED WORKLAMPS

FOR MARINE APPLICATIONS



TLL-10M



TLL-27M



TLL-70M



TLL-130M



TLB-80M



TLB-160M

MODEL	LUMENS	WATTS	LEDS	SIZE H/W/D"	VOLTS	BEAM
TLL-10M	900	10	1	3-1/2 x 2-1/2 x 3	10-32	FLOOD
TLL-27M	1,800	27	9	5 x 4-1/2 x 2	10-32	FLOOD
TLL-27SM	1,800	27	9	5 x 4-1/2 x 2	10-32	SPOT
TLL-70M	6,300	70	7	6-3/4 x 6 x 3-1/2	10-32	COMBO
TLB-80M	7,200	80	8	12 x 3-1/2 x 3-1/2	10-32	COMBO
TLL-130M	10,140	130	13	9 x 8 x 5-3/4	10-32	COMBO
TLB-160M	14,400	160	16	23 x 3-1/2 x 3-1/2	10-32	COMBO

COMMON FEATURES

- CREE LEDs
- Die Cast, Aluminum Alloy Body
- High-Impact Lexan Polycarbonate Anodized Lens
- White Polyester Powder Coating
- Waterproof IP68 Rating
- CE/E-mark Certified

All Triton Work Lamps Carry a 10-Year Warranty

RUGGED 60-DEGREE ANGLE LED WORK-LAMPS

IDEAL FOR WORK TRUCK, BOX TRUCK, RV OR BOAT



TLC-82 (WHITE ONLY)

- Dimensions: 8" x 1.5" x 1.5" (W/H/D)
- 6 pcs 3W SMD LEDs (18 Watts)
- Cast Aluminum Housing
- Intensity: 1,000 Lumens
- 12/24 Volts



TLC-93B (BLACK) TLC-93W (WHITE)

- Dimensions: 9" x 3" x 3" (L/H/D)
- 18 pcs 1W SMD LEDs (18 Watts)
- Cast Aluminum Housing Intensity:
- 1,450 Lumens
- 12/24 Volts



TLC-133B (BLACK) TLC-133W (WHITE)

- Dimensions: 13" x 3" x 3" (W/H/D)
- 27 pcs 1W SMD LEDs (27 Watts)
- Cast Aluminum Housing
- Intensity: 2,250 Lumens
- 12/24 Volts

Triton 5-Year Limited Warranty

AFTERMARKET LED REPLACEMENTS FOR DEERE COMPACT TRACTOR LAMPS MODEL: TSL-2STT

DROP-IN LED REPLACEMENT FOR TRACTOR HALOGEN LAMPS.
INCLUDES OPTIONALLY WIRED BACK-UP LAMPS



REPLACES OLDER HALOGEN
OEM LAMPS SHOWN BELOW

*** SOLD ONLY IN PAIRS ***



FEATURES:

- **DOT CONFORMING**
- **BRIGHTER THAN OEM LAMPS**
- **HERMETICALLY SEALED TO IP69**
- **DROP-IN REPLACEMENT**
- **RUGGED ALUMINUM MOUNT**
- **POLYCARBONATE LENSES**
- **USES ORIGINAL MOUNTING BOLTS**
- **USES ORIGINAL MOUNTING BOLTS**
- **3 YEAR WARRANTY**
- **INCLUDES BACK-UP LAMPS**

Triton 3-Year Limited Warranty

DEERE GATOR LED LIGHT-BAR PLUG 'N PLAY UPFITTING KIT



- **HIGH-POWER 12-INCH 7,000 LUMENS LED LIGHT-BAR**
- **FEATURES**
- **FITS GATOR MODELS XUV835/860**
- **FORM-FITTING WIRING HARNESS**
- **OEM ILLUMINATED SWITCH**
- **STAINLESS STEEL LAMP HARDWARE**
- **TRUE PLUG & PLAY KIT**
- **PLUGS DIRECT INTO EXISTING ELECTRICAL SYSTEM**
- **WEATHERPROOF DEUTSCH CONNECTORS**
- **INSTALLS IN APPROXIMATELY 45 MINUTES**

13-INCH LIGHT-BAR KIT: TWHK-80LP
2 LAMPS FRONT KIT: TWHK-223
4 LAMPS FRONT/REAR KIT: TWHK-423



HIGH-INTENSITY LED LIGHT BARS

TM

- 9-INCH LENGTH 16-LED 48 Watt Model # TLB-48: 3,800 Lumens
- 12-INCH LENGTH 8-LED 80 Watt Model # TLB-80LP: 7,200 Lumens
- 21-INCH LENGTH 40-LED 120 Watt Model # TLB-120: 8,500 Lumens
- 23-INCH LENGTH 16-LED 160 Watt Model # TLB-160LP: 14,400 Lumens
- 36-INCH LENGTH 24-LED 240 Watt Model # TLB-240LP: 21,600 Lumens

Rugged Aluminum Alloy with Attractive Black Anodized Finish
Combo Models: Inner LED's Spot and Outer LEDs Flood



**TLB-48
9-INCH**



**TLB-80LP
12-INCH**



TLB-160LP



TLB-120



TLB-240

Triton 3-Year Limited Warranty

HIGH QUALITY LED LAMP BRACKETS FOR TRACTORS AND LAWNMOWERS

THE TRITON ROPS BRACKETS SERIES ARE HEAVY-DUTY ALLOY BRACKETS WHICH FIT THE THREE MOST COMMON ROPS SIZES.



FEATURES

- ANODIZED ALUMINUM BRACKETS
- SILICONE INNER SLEEVE
- STAINLESS STEEL HARDWARE
- INTERNAL BOLT HEAD RECESSES

FITS ROPS DIMENSIONS

- 3" X 1.5" MODEL TRB-3X15
- 2" X 2" MODEL TRB-2X2
- 2" X 1" MODEL TRB-2X1

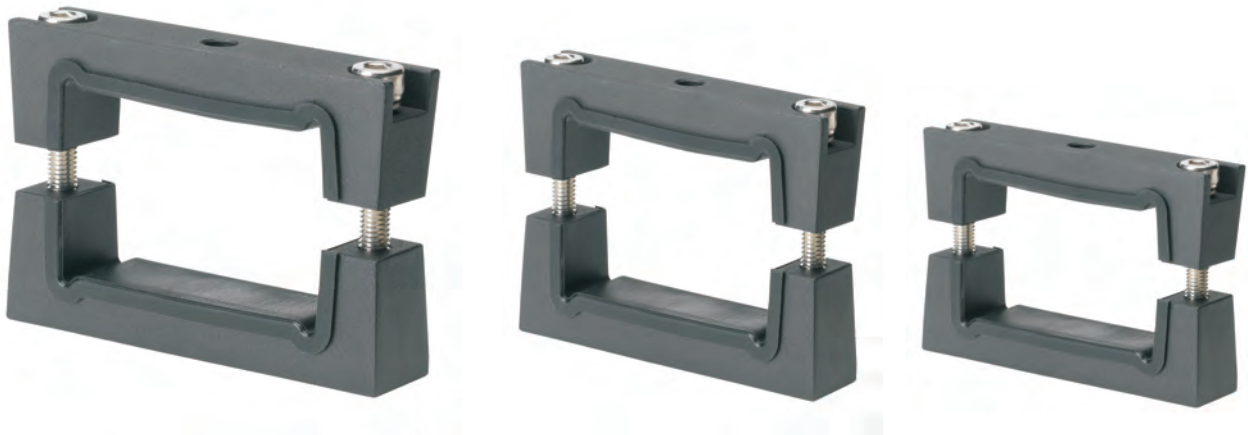

WWW.TRITON-SIGNAL.COM

TWH SERIES HARNESS KITS FOR LIGHTBAR OR DUAL LAMPS

**TWH-1
LIGHT-BAR
HARNESS KIT**



**LABOR-
SAVING
PLUG-'N PLAY
EASY SWITCH INSTALL
UP TO 480 WATTS LIGHT-BAR
OR TWO 240 WATT LAMPS**

- EASY PLUG-'N-PLAY INSTALL KIT
- 16FT POWER POINT TO LAMPS WIRING
- 40 AMP RELAY HANDLES UP TO 480 WATTS
- ILLUMINATED POWER SWITCH WITH HOLE TEMPLATE
- SEALED DEUTSCH PLUGS



SWITCH CONNECTIONS AND MOUNTING HOLE DETAILS

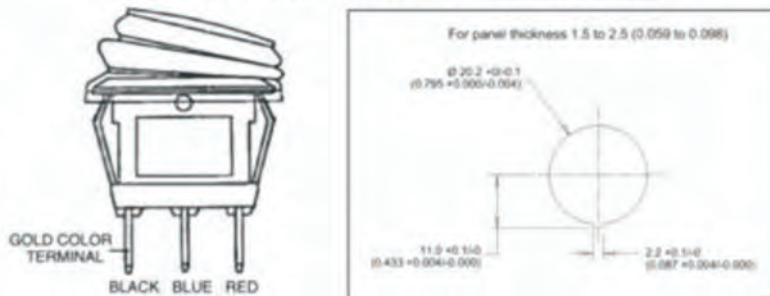

**ILLUMINATED EASY-
INSTALL POWER SWITCH**

**POWER SWITCH WITH TEMPLATE AND
DRILLING AND WIRING INSTRUCTIONS**

**PLUG-'N PLAY
EASY SWITCH INSTALL
TWO 240 WATT LAMPS**

**TWH-2
DUAL-LAMP
HARNESS KIT**



TRITON "STING-RAY" TRL-60

REMOTE CONTROLLED BLUETOOTH SEARCH LAMP

FEATURES OF TRL-60

- Working Voltage: 10-30 VDC
- Power output: 60 Watts
- 60° tilt, 360° Rotation
- Color Temperature: 6000K
- Bluetooth control
- Light Power: 4800 Lumens
- Remote Controller range:100ft
- Beam Pattern: Spot 8°
- Waterproof: IP65
- Cord length: 10ft
- CREE LED's
- Mount: Magnetic / Bracket



MAGNETIC SEARCH LIGHT WITH HAND-HELD REMOTE CONTROLER AND BLUETOOTH SMART PHONE CONTROL CAPABILITY

TRITON "PANTHER" TRL-45

RADIO CONTROLLED WORK LAMP

Voltage	DC12/24V
Power	35W
Light Source	LED
Lumens	3240 Lm
Remote Control Distance	>30m (up to 100m)
Waterproof	IP65
Working Temperature	-40° to +55C
Size	12.5" x 9" x 7" (folded down)



FULLY REMOTE CONTROLLED UP TO 100 FT AWAY SELF PARKING FEATURE POWERFUL 3,240 LUMENS LED SEARCH LAMP



TLH-38H

SNOW PLOW DOT HEADLAMPS WITH **THRUST-HEATED** LENS



- **WORKING VOLTAGE: 10-30 VDC**
- **POWER: 30 WATTS**
- **COLOR TEMPERATURE: 6000K**
- **AUTOMATIC THERMO-CONTROLLED THRUST-HEATED LENS**
- **DOT CERTIFIED**
- **5-FUNCTIONS: HI/LOW, RUNNING LIGHTS, TURN SIGNAL, PARKING**
- **90 DEGREE (VERTICAL TO HORIZONTAL) MOUNTING BRACKET**
- **WATERPROOF IP69**
- **10FT HARNESS WITH SEALED DEUTSCH PLUGS**
- **STAINLESS STEEL SUPER-DUTY MOUNTING BRACKETS**

TRITON 3-YEAR WARRANTY

SELECTIVE YELLOW SNOW PLOW AND SALT SPREADER LAMPS



TLL-16A

CONTINUOUS 1,260 LUMENS
AMBER WORKLAMP
DIMENSIONS: 5" x 4" x 2" (H/W/D)

TLB-80LPY

CONTINUOUS 7,200 LUMENS
TLB-160LPY
CONTINUOUS 14,400 LUMENS
SELECTIVE YELLOW
SNOW DRIVING LIGHT-BARS

TWL-6A

1,260 LUMENS QUAD-FLASH
AMBER STROBE
DIMENSIONS: 5" x 4" x 2" (H/W/D)

SPECIFICATIONS

High-Intensity CREE LED's
10 to 30 Volts Operation
Waterproof to IP67
Reverse Polarity Protected
Rugged Cast-Alloy Housing
Shatterproof Polycarbonate Lens

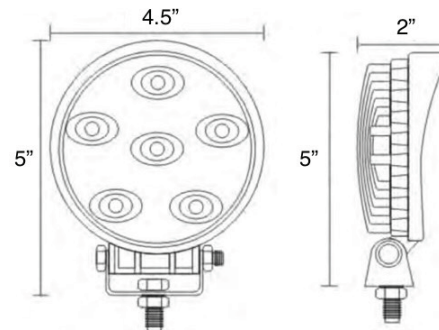

BELOW IMAGES SHOW THE EFFECT ON DRIVING-VISION OF WHITE VERSUS YELLOW LAMPS IN SNOW



Triton 3 -Year Limited Warranty

SNOW PLOW AND SALT SPREADER LAMPS



**27 WATTS
WHITE AND YELLOW**



**YELLOW/
CLEAR COMBO
LAMP**

TLL-27YW

**40 WATTS
HEATED LENS**



**HEATED
LENS**

TLL-40H

**50 WATTS
SELECTIVE YELLOW**



**HEATED
LENS**

TLL-50Y

SPECIFICATIONS

- Shatterproof Polycarbonate Lens
- Rugged Aluminum Housing High
- Intensity CREE LEDs
- Intensity: 2,100 Lumens
- 10 to 30 Volts D.C.
- Waterproof to IP69 Dimensions:
- 4.5" x 4.5" x 2.4"

SPECIFICATIONS

- Shatterproof Polycarbonate Lens
- Rugged Aluminum Housing High
- Intensity CREE LEDs
- Intensity: 4,100 Lumens
- 10 to 30 Volts D.C.
- Waterproof to IP69 Dimensions:
- 4.5" x 4.5" x 2.4"

SPECIFICATIONS

- Shatterproof Polycarbonate Lens
- Rugged Aluminum Housing High
- Intensity CREE LED
- Intensity: 4,800 Lumens
- 10 to 30 Volts D.C.
- Waterproof to IP69 Dimensions:
- 4.5" x 4.5" x 2.4"

Triton 3-Year Limited Warranty

TLHB SERIES LED BULBS

Drop-in replacements for most common headlamp filament-bulbs.



- Working Voltage: 9 to 32 Volts DC.
- Power Output: 30 Watts Each.
- Color Temperature: 5000K.
- Body: Aviation Grade Aluminum.
- Thermo-Controlled Cooling Fan.
- Light Power: 15,000 Lumens.

Triton 3-Year Limited Warranty.



SUN-SPOT™

DOT CERTIFIED LED HEADLAMP UPGRADES

REPLACE with TRITON #	
H1	TLHB-H1
H3	TLHB-H3
H4	TLHB-H4
H7	TLHB-H7
H9	TLHB-H9
H10	TLHB-H10
H11	TLHB-H11
H13	TLHB-H13
9004	TLHB-9004
9005	TLHB-9005
9006	TLHB-9006
9007	TLHB-9007

*** PRICED AND SUPPLIED ONLY IN BOXED PAIRS ***

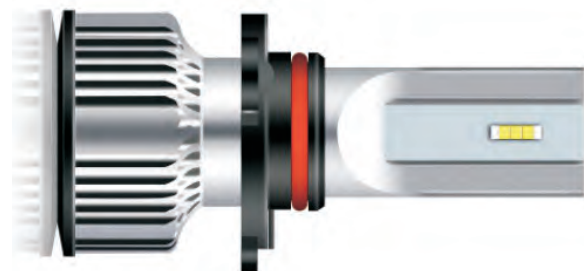

ACTUAL SIZE SHOWN

TLTB SERIES LED BULBS
 Drop-in LED replacements for most common foglamp, interior and tail-lamp bulbs.



**INTERIOR LAMP FOG-LAMP
 AND TAIL LAMP
 LED UPGRADES**

- Working Voltage: 9 to 16 Volts DC.
- Power Output: 20 Watts Each
- Light Source: Upgraded New 1860 LED Chips
- Color Temperature: 5000K
- Body: High-Temperature Polycarbonate
- Light Power: 1,500 Lumens
- Internal Resistor

Triton 3-Year Limited Warranty

REPLACE WITH TRITON #	
194	TLTB-194
921	TLTB-921
1156	TLTB-1156
1157	TLTB-1157
3156	TLTB-3156
3157	TLTB-3157
7440	TLTB-7440
7443	TLTB-7443
H7	TLTB-H7
H9/H11	TLTB-H9/H11
9005	TLTB-9005
9006	TLTB-9006



ACTUAL SIZE SHOWN

*** PRICED AND SUPPLIED ONLY IN PAIRS ***



COMMON WEDGE-BASE TYPES

SUNBEAM™ SERIES

ROUND AND RECTANGULAR REPLACEMENT LED HEADLAMP UNITS

DOT AND SAE CERTIFIED



- Working Voltage: 9 to 32 Volts DC.
- Power Output: 30 Watts Each.
- Color Temperature: 5000K.
- Body: Aviation Grade Aluminum.
- Thermo-Controlled Cooling Fan.
- Light Power: 15,000 Lumens.

**★ PRICED AND SUPPLIED
ONLY IN BOXED PAIRS ★**



TLH-5D (UPGRADE 9007 HIGH/LOW) 5.25" HEADLAMPS
TLH-5S (UPGRADE 9005 SINGLE BEAM)



TLH-64D (UPGRADE 9007 HIGH/LOW) 6" X 4" HEADLAMPS
TLH-64S (UPGRADE 9005 SINGLE BEAM)



TLH-75D (UPGRADE H4 HIGH/LOW) 7" X 5" HEADLAMPS



TLH-7D (UPGRADE H4 HIGH/LOW) 7" HEADLAMPS

1-877-874-3744

www.triton-signal.com

Triton 3-Year Limited Warranty

BLUE POINT™ SPOT PROJECTION LED SAFETY LAMP

TLL-21 BLUE-POINT SPOT PROJECTOR

Avoids potential accidents by projecting a clear blue spot on the ground a distance ahead of - or behind - the vehicle.



- Working Voltage: 9 to 60 Volts DC
- Power output: 10 Watts
- Color Temperature: 6000K
- Lens: Impact-Resistant Polycarbonate
- Body: Cast Aluminum
- Light Power: 750 Lumens
- Current Draw: Max 0.7 Amps (12 Volts)

TYPICAL APPLICATIONS:

- MOBILE AGRICULTURAL MACHINERY
- GAS & ELECTRIC POWERED FORKLIFTS
- SKID-STEERS
- PICKUP TRUCKS
- COMMERCIAL VEHICLES

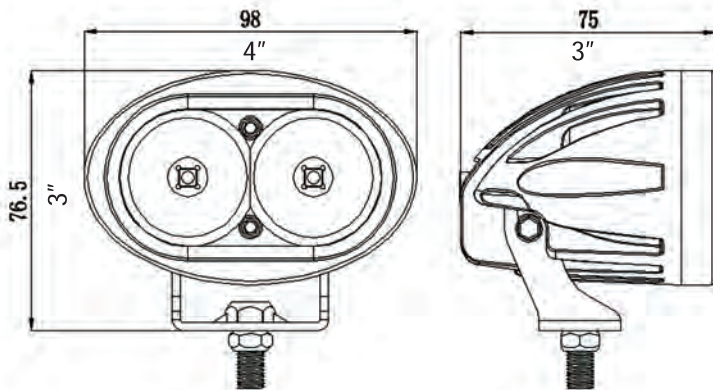



TLL-15V

- White, 5x3 Watt High-intensity CREE LEDs
- 4" Square Cast Aluminum Sealed Housing
- 10-60V DC
- Polycarbonate Lens
- 15 Watts Flood
- 950 Lumens



TLL-21

- Forklift Reversing Lamp
- Intense Blue, 2x5 Watt High-Intensity Cree LEDs
- 5.5" x 3.5" Oval Cast Aluminum Sealed Housing
- 10-60V DC
- 10 Watts Spot
- 750 Lumens



TLL-22R

- Forklift Safety Clearance Lamp
- Intense Red, 2x3 Watt High-Intensity Osram LEDs
- 2.5" x 2" x 2" Cast Aluminum
- 10-80V DC
- 180 Lumens



TLL-24R

- Forklift Safety ARC Line
- Rear Clearance Lamp
- Intense Red, 2x5 Watt High-Intensity Osram LEDs
- 3.5" x 3.5" x 3" Cast Aluminum
- 10-80 V DC
- 200 Lumens



TLL-25V

- White, 5x5 Watt High-Intensity CREE LEDs
- 4" Square Cast Aluminum sealed Housing
- 10-60V DC
- Polycarbonate Lens
- 25 Watts Flood
- 2100 Lumens



Back-up Alarm TB17E

- 87dB Sound Level
- 12 through 80 Volts
- w/1ft Wires
- 3 Year Warranty



TWB-34A

- Forklift Strobe Lamp
- High-Intensity
- 5" x 3" x 3.75" (H/W/D)
- Polycarbonate
- SAE Class 3
- 10-80V DC

FORKLIFT SAFETY ARC LINE REAR CLEARANCE LAMP



TLL-24R (RED) 

TLL-24B (BLUE) 

TLL-24RB (RED & BLUE) 



- Forklift Safety ARC Line Rear Clearance Lamp
- Sharply-Defined ARC
- 1x10 Watt High-Intensity LED
- 5.5" x 4.0" x 3.5" (H/W/D)
- Cast Aluminum
- IP67 Water-Resistance rated
- 10-80V DC
- Work temperature -40C - 65C
- 200 Lumens

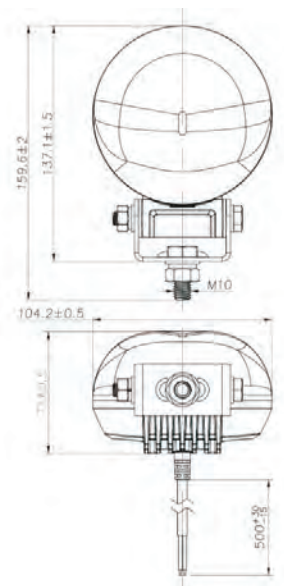
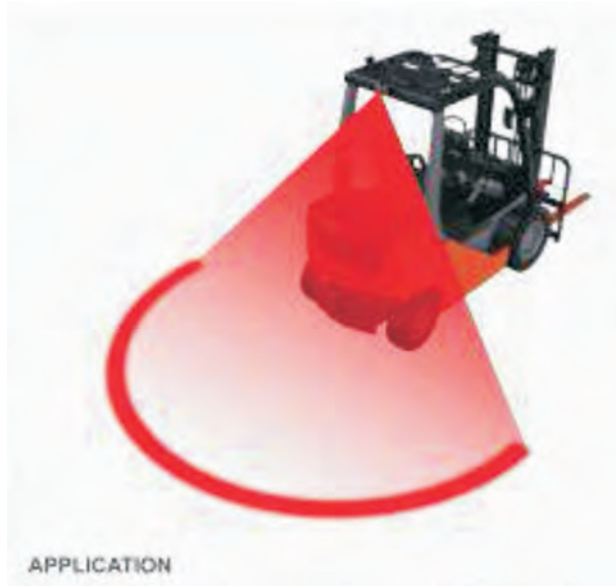

FORKLIFT LED BEACON

MODELS TWB-33A & TWB-34A



TWB-33A

- Forklift compact amber warning lamp
- Multi-Voltage: 10 to 80 Volts DC
- SAE Class-3
- Strong polycarbonate Lens
- Two-hole bracket
- Multiple high-output LEDs for even light dispersion
- 5-year warranty
- Low current draw: 500 milliamps
- High purity color and illumination
- Water resistant to IP67
- Smooth outside Lens resists dust build-up
- Dimensions 5" x 3" x 3.75" (H/W/D)
- Mounting Holes Pitch 3.5"



TWB-34A

- Forklift compact amber warning lamp
- Multi-Voltage: 10 to 80 Volts DC
- SAE Class-3
- Strong polycarbonate Lens
- Two-hole bracket
- Multiple high-output LEDs for even light dispersion
- 5-year warranty
- Low current draw: 500 milliamps
- High purity color and illumination
- Water resistant to IP67
- Dimensions 5" x 3" x 3.75" (H/W/D)
- Mounting Holes Pitch 3 3/8"

FORKLIFT TFS-200 LED TAIL-BLAZER™ STRIPS



**FORKLIFT BACK-UP WARNING STRIPS
MAGNETIC INSTALLATION - PLUG & PLAY**

**SIMPLE TWO WIRE CONNECTION TO
BACK-UP CIRCUIT**

STRIPS SNAP MAGNETICALLY TO ROPS

**RED LIGHT WARNS BYSTANDERS
WITHOUT AFFECTING NIGHT-VISION**

**SUPPLEMENTS ON-GROUND WARNING
LINES WITH ADDED BACK-UP WARNING**

WORKS ON 12, 24, 36 & 48 VOLT SYSTEMS

3 YEAR WARRANTY





FORK-LIGHTNING

FORKLIFT LASER TINE POSITIONING SYSTEM

MODEL TFG-13 IS A SELF-CONTAINED, LITHIUM-BATTERY POWERED LASER SYSTEM FOR USE ON FORKLIFT TRUCKS, TO SUPPLEMENT THE OPERATOR'S ABILITY TO ACCURATELY POSITION THE FORKLIFT AND FORK TINES TO PICK LOADS.

SYSTEM COMPONENTS

1. LITHIUM-ION 12-VOLT POWER UNIT - MAGNETIC
2. CHARGER 110 V. FOR POWER UNIT CHARGING
3. MAGNETIC LASER UNIT
4. INFRA-RED SWITCH UNIT - MAGNETIC
5. HARNESS ZIP-TIES - MAGNETIC (2)

POWER UNIT WITH FLASHING GREEN LAMP AND RED LASER BELOW

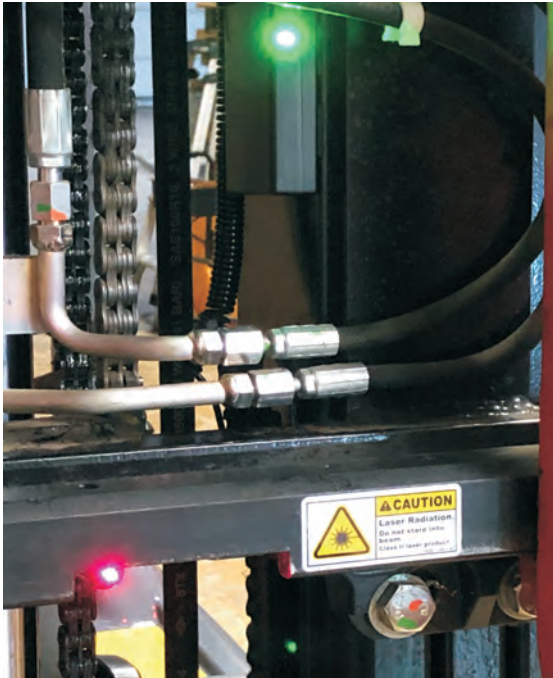

BRIGHT RED LASER LINE SHOWS FORK TINES POSITIONING



SPEEDY INSTALLATION

ALL COMPONENTS ARE MAGNETICALLY ATTACHED IN MINUTES USING HIGH-POWERED, SILICONE-COATED, RARE-EARTH MAGNETS

SENSOR SWITCHED

LASER IS ONLY TURNED ON WHEN FORKS ARE RAISED. CONSERVES BATTERY POWER AND EXTENDS CHARGING CYCLES

FORKLIFT CAMERA SYSTEM

TFCS-700RC

THE TFCS-700RC IS A SELF-CONTAINED, LITHIUM-BATTERY POWERED CAMERA SYSTEM FOR USE ON FORKLIFT TRUCKS, TO SUPPLEMENT THE OPERATOR'S ABILITY TO POSITION FORK TINES IN HIGH-REACH FORKLIFT APPLICATIONS AND/OR VIEW OVER THE LOAD TO SUPPLEMENT SAFETY DURING TRANSPORTING OF LOADS.

SYSTEM COMPONENTS

1. WIRELESS MONITOR 7-INCH COLOR 2-CHANNEL
2. WIRELESS CAMERA 12 VOLT - MAGNETIC
- 3A. LITHIUM-ION (STANDBY) 12-VOLT POWER UNIT – MAGNETIC
- 3B. LITHIUM-ION (MAIN) 12-VOLT POWER UNIT – MAGNETIC
4. CHARGER 110 V. FOR POWER UNIT CHARGING.
5. MONITOR MOUNTING BRACKET
6. REMOTE CONTROLLER SWITCH UNIT – MAGNETIC, WITH CONTROL FOB
7. ANTENNAS FOR CAMERA AND MONITOR (2)



AMBER WARNING LIGHTS



TWB-33A



TWB-34A



TWB-42AM



TWB-44A



TMF-50A



TMF-55A



TWB-63A



TWB-65A



TWB-66A



TWB-67A/AM



TWB-46A-DIN



WB-58A-DIN



TMF-65ARC

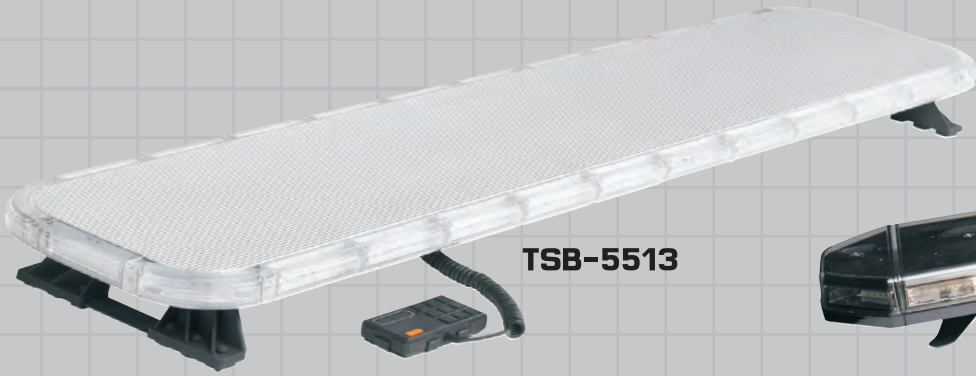

TSB-5513



TSB-4512



TMB-1812

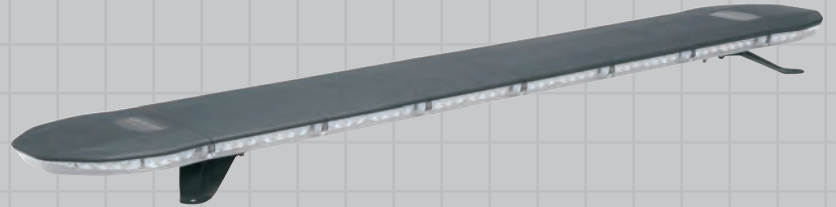

TSB-5308



TMB-107



TMB-159



TDS-12



TMB-108



TMB-126A



TLP-126A



TMB-117



TWS-6A

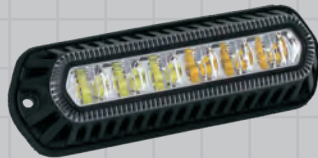

TGS-6AC



TUS-6AC



TSS-6



TLP-44A2

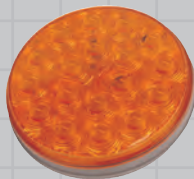

TWB-400A



TWB-600A



TCS-2



TSS-12

TSFM SUPER-NOVA™ THRU-HOLE FLUSH-MOUNT STROBES



- THROUGH-HOLE FLUSH-MOUNT DESIGN
- RUGGED DIECAST ALUMINUM HOUSING
- POLYCARBONATE (PC) LENS
- OPERATING VOLTAGE: 10 TO 32 VOLTS
- SEALED IP67 DESIGN
- HIGH INTENSITY SAE CLASS-1 OUTPUT
- INTEGRATED CONTROL CIRCUITRY
- OPTIONAL 90 DEGREE STEEL BRACKET

TSFM-4 SINGLE AND DUAL COLORS

- TSFM-4C: SINGLE **WHITE**
- TSFM-4A: SINGLE **AMBER**
- TSFM-4AC: DUAL **AMBER/WHITE**
- TSFM-4AG: DUAL **AMBER/GREEN**
- TSFM-4G: SINGLE **GREEN**
- TSFM-4R: SINGLE **RED**
- TSFM-4RB: DUAL **BLUE**
- TSFM-4RB: DUAL **RED/BLUE**

Triton 3 Year Limited Warranty



ACTUAL SIZE
7/8"X1.3" (D/L)



**L-BRACKET AVAILABLE FOR
PURCHASE SEPARATELY AS TSFM-BKT**



MOUNTING GROMMET INCLUDED

CONCEALED LED STROBE SYSTEM

MODEL THS-2



DUAL-HEAD THS-2A: AMBER
 DUAL-HEAD THS-2AC: AMBER/CLEAR
 DUAL-HEAD THS-2AG: AMBER/GREEN
 DUAL-HEAD THS-2C: CLEAR



- Small Light-Head for internal mount within composite headlamps, turn-lamps and tail-lamps
- Selectable flash patterns with auto-synchronize features
- Lens design enhances light distribution
- Surface mount bezels (Black and Chrome)
- Base mounts vertically or horizontally
- Available in Amber, White, White/Amber, Amber/Green Or Clear
- Durable, polycarbonate lens for maximum impact resistance

Units = Inches

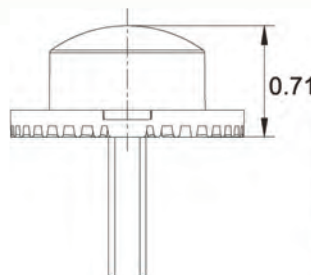
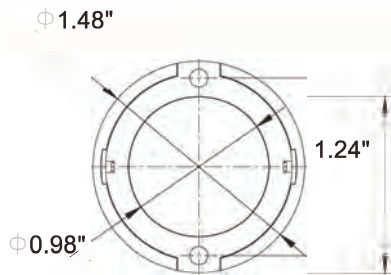

CHROME BEZELS & BLACK BEZELS INCLUDED

Technical Data:

Tech Specs:

Flash patterns:	14 flash patterns
Mounting:	Headlight, Taillight or Surface Mount with optional Bezels
Input Voltage:	10-32V
Colors choice:	Amber Amber/White
Operations Temperature:	-40°to + 65°C

Triton 5-Year Limited Warranty



TWS "WAFER STROBE" SERIES



TWS-4A (AMBER) TWS-4AC (AMBER/WHITE) TWS-4C (WHITE)

ALL MODELS ARE 0.25" THICK



- INPUT VOLTAGE: 10~33V DC
- 3 WATT LEDS
- SAE CLASS-1
- SHATTERPROOF PC LENS
- WATERPROOF - IP68
- MULTIPLE FLASH PATTERNS



TWS-6A (AMBER) TWS-6AC (AMBER/WHITE) TWS-6AG (AMBER/GREEN)



SINGLE COLOR AND DUAL COLOR 50/50 MODELS



TWS-12 MODEL - AVAILABLE COLORS

- AMBER ONLY: TWS-12A
- AMBER/WHITE (SPLIT): TWS-12AC
- RED/BLUE (SPLIT): TWS-12RB
- AMBER/GREEN (SPLIT): TWS-12AG

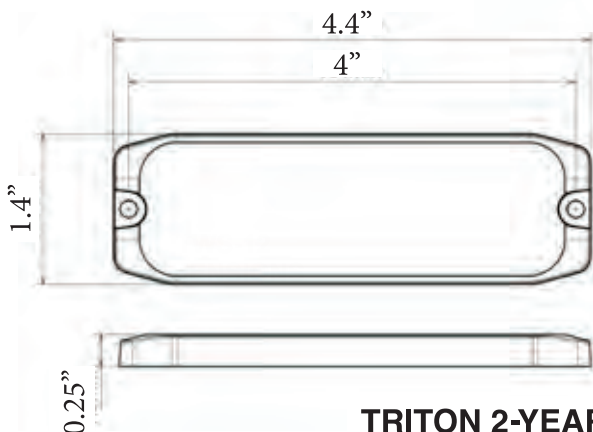

TRITON 2-YEAR LIMITED WARRANTY

SNAKE-EYE™

AMBER GRILL STROBE

TGS-6 SERIES

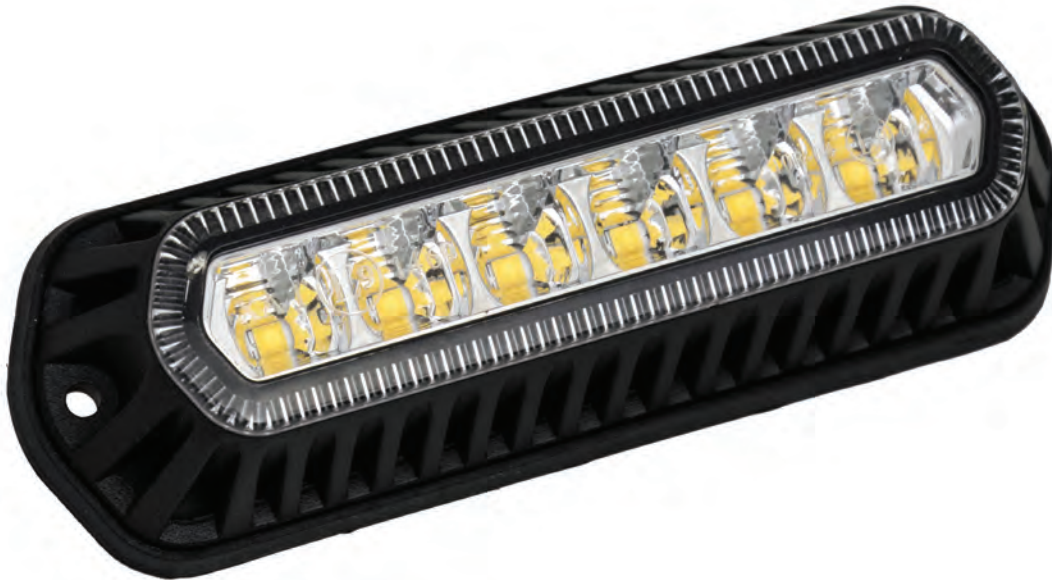

ACTUAL SIZE: 5.5" x 1.4" x 2" (W/D/H)

- **RUGGED, SAE CLASS-1**
- **GRILL-MOUNT HIGH INTENSITY**
- 6 High intensity 3 watt LEDs
- Low current draw, high lumens output
- 10 to 30 Volts DC operation
- SAE J845 Class 1 certified
- 22 Pre-selectable flash patterns
- Last flash pattern memory
- Shatterproof polycarbonate lens
- Polycarbonate aluminum-coated reflector
- Cast aluminum housing
- Two-bolt mounting

MODEL: TGS-6A (Amber)

MODEL: TGS-6C (Clear)

MODEL: TGS-6AC (50/50 Amber/Clear LEDs)

MODEL: TGS-6R (Red)

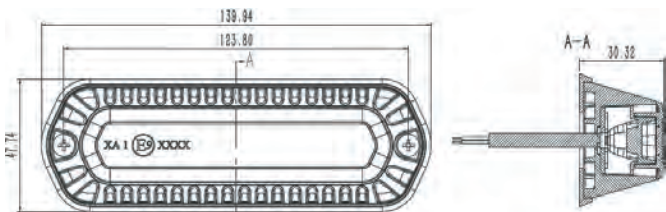
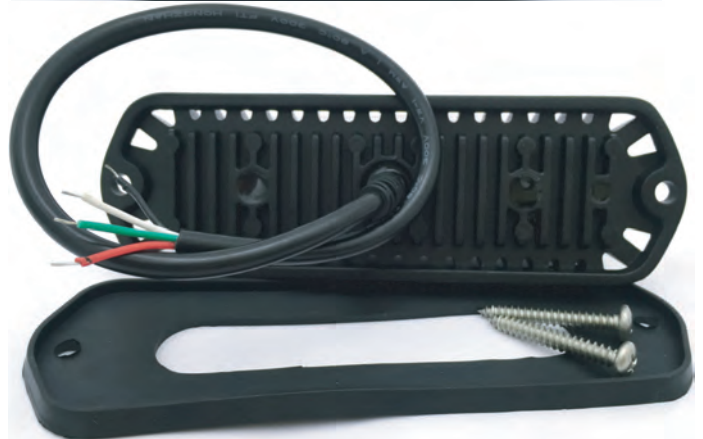

Triton 5-Year Limited Warranty.

SNAKE-EYE™

UNIVERSAL-MOUNT AMBER STROBE

TUS-6 SERIES

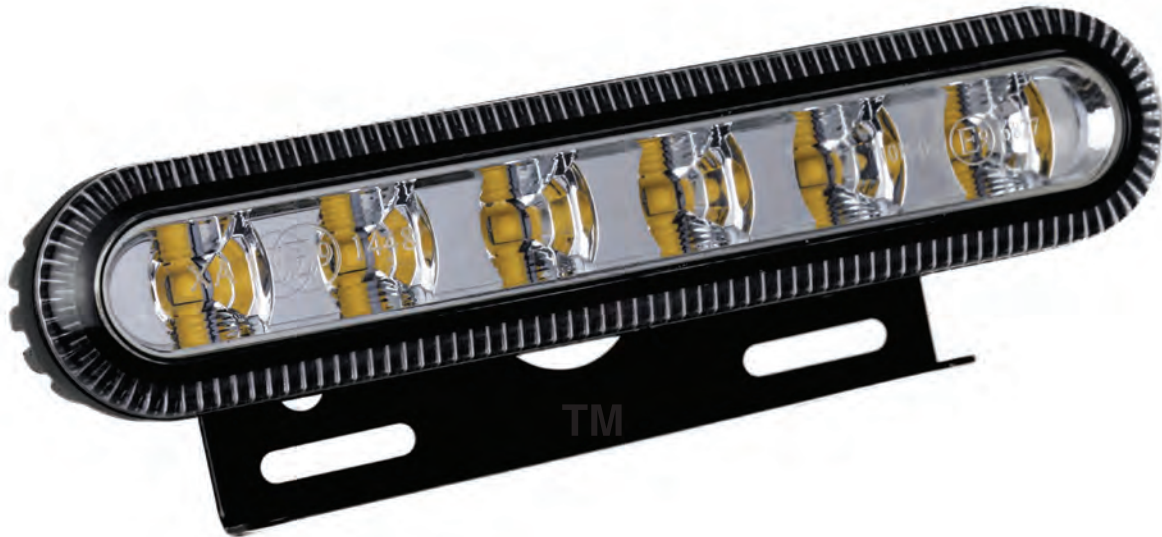

ACTUAL SIZE: 5.5" x 1.4" x 1.2" (W/D/H)

- **RUGGED, SAE CLASS-1**
- **UNIVERSAL HIGH INTENSITY**
- 6 High intensity 3 watt LEDs
- Low current draw, high lumens output
- 10 to 30 Volts DC operation
- SAE J845 Class 1 certified
- 22 Pre-selectable flash patterns
- Last flash pattern memory
- Shatterproof polycarbonate lens
- Polycarbonate aluminum-coated reflector
- Cast aluminum housing
- Universal mount with L-bracket
- Reverse polarity protected

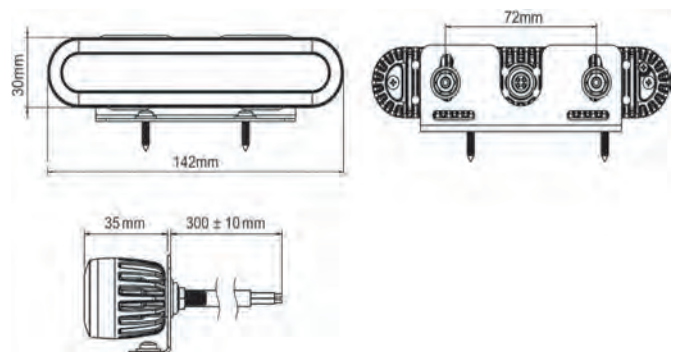

UNIVERSAL TYPE WITH L-BRACKET
MODEL: TUS-6A (Amber)
MODEL: TUS-6C (Clear)
MODEL: TUS-6AC (50/50 Amber/Clear LEDs)
MODEL: TUS-6R (Red)

Triton 5-Year Limited Warranty

SURFACE STROBE TSS-6 SERIES

TSS-6



TSS-12



TSS-3



TSS-4



RUGGED, SAE CLASS-1 HIGH INTENSITY SURFACE STROBES

- Low current draw, high lumens output
- TSS-4, TSS-6 Single Color 15 Selectable flash patterns
- Dual color 8 Selectable flash patterns
- TSS-3, TSS-12 19 Selectable flash patterns
- Last flash pattern memory
- Shatterproof polycarbonate lens
- Polycarbonate aluminum-coated reflector
- Cast aluminum housing
- Universal mount with L-bracket
- Reverse polarity protected

AVAILABLE COLORS:

- TSS-3A: Amber
- TSS-3C: Clear
- TSS-4A: Amber
- TSS-4A/C: Amber/Clear
- TSS-6A: Amber
- TSS-6AC: Amber/Clear
- TSS-6C: Clear
- TSS-6R: Red
- TSS-6B: Blue
- TSS-6AB: Amber/Blue
- TSS-6AG: Amber/Green
- TSS-6BR: Blue/Red
- TSS-6RC: Red/Clear
- TSS-12A: Amber
- TSS-12AC: Amber/Clear
- TSS-12AB: Amber/Blue
- TSS-12AG: Amber/Green

SPECIFICATIONS TSS-3

LIGHT SOURCE	3X3 WATT LEDs
SIZE	2.75" x 1" x 0.4"
WATERPROOF	IP68
WORKING TEMP	-14°F to 149°F
VOLTAGE	10 - 30V
WATTAGE	9 Watts

SPECIFICATIONS TSS-4

LIGHT SOURCE	4X3 WATT LEDs
SIZE	3.74" x 1.18" x 0.51"
WATERPROOF	IP6K9K
WORKING TEMP	-14°F to 149°F
VOLTAGE	10 - 30V
WATTAGE	9 Watts

SPECIFICATIONS TSS-6

LIGHT SOURCE	6X3 WATT LEDs
SIZE	4.79" x 1.18" x 0.51"
WATERPROOF	IP68
WORKING TEMP.	-14°F to 149°F
VOLTAGE	10 - 30V
WATTAGE	12 Watts

SPECIFICATIONS TSS-12

LIGHT SOURCE	12X3 WATT LEDs
SIZE	4.25" x 1.5" x 0.5"
WATERPROOF	IP68
WORKING TEMP.	-14°F to 149°F
VOLTAGE	10 - 30V
WATTAGE	36 Watts

Triton 3-Year Limited Warranty

TWB-400A & TWB-600A LED FLUSH-MOUNT STROBES

**SAE CLASS-1
GROMMET-MOUNT
STROBE-LIGHT**



SIZE: 4"x 4"x 1" (L/W/H)

TYPICAL APPLICATIONS:

- **UTILITY TRUCKS**
- **CONSTRUCTION TRUCKS**
- **PICKUP TRUCKS**



**AMBER: TWB-600A
AMBER/GREEN: TWB-600AG**



TWB-400A

FEATURES:

- 6 Different, Selectable Flash Patterns.
- Power Level: SAE Class-1.
- Voltage: 10 to 16 Volts DC.

- Base and Mounting Feet: Aluminum.
Available in AMBER or AMBER/GREEN



SIZE: 6.5"x 2.25"x 1" (L/W/H)

Triton 5 Year Limited Warranty

DASH/VISOR-MOUNT STROBE-LAMP MODEL TDS-12

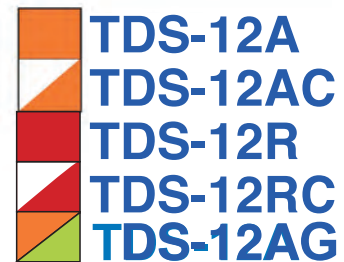

**RUGGED, SAE CLASS-1
HIGH INTENSITY**

**AMBER MODEL: TDS-12A
AMBER/WHITE MODEL: TDS-12AC
RED MODEL: TDS-12R
RED/WHITE MODEL: TDS-12RC
AMBER/GREEN MODEL: TDS-12AG**

- 8 LED Light-Head
- 3 Watt LEDs
- 19 Selectable Flash Patterns
- DC 12~24V
- Dimensions: 8"L x 3"W x 2"H
- 3-Meter wire with Cigar Plug
- 3 Suction Cups or Screws Mount
- SAE J595 CLASS 1 Double Flash



Triton 3-Year Limited Warranty

WARNING BEACON AMBER LED MODELS TWB-42A / TWB-44A / TWB-44AA

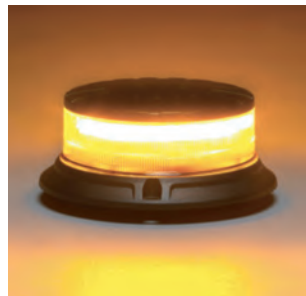

MODEL TWB-42AM

ECE R65, TA2, SAE CLASS-1

MAGNA MOUNT STROBE LIGHT

- 360 Degree Magnetic
- SAE J845 Class-1 Certified
- Reverse Polarity Protected
- 12 Flash Patterns
- Shatterproof Polycarbonate lens and base

SPECIFICATIONS

VOLTAGE	12-32 VDC
LIGHT SOURCE	32 LEDS
CHARGER	CIGAR PLUG (Magnetic mount)
FLASH PATTERNS	12 Flash Patterns
WATERPROOF	IP67 Protection Standard
WORKING TEMPERATURE	-22F to 122F
SIZE	2"x 4" (Height/Diameter)

MODEL TWB-44A/AM

SAE CLASS-1 and E9 Certified

FIXED / MAGNETIC MOUNT

- Three bolt surface mount TWB-44A
Magnetic mount TWB-44AM
Pipe mount/Aluminum base TWB-44AA
- 12 Flash Patterns
- Reverse Polarity Protected
- Shatterproof Polycarbonate lens and base

SPECIFICATION

VOLTAGE	12-32 VDC
LIGHT SOURCE	32 LEDS
CHARGER	CIGAR PLUG (Magnetic mount)
FLASH PATTERNS	12 Flash Patterns
WATERPROOF	IP67 Protection Standard
WORKING TEMPERATURE	-22F to 122F
SIZE	4"x 5" (Height/Diameter)

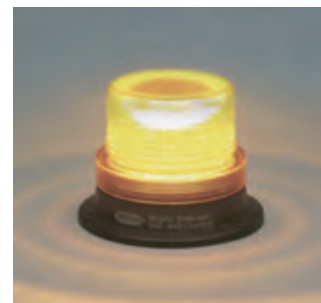

Triton 3-Year Limited Warranty

AMBER LED WARNING BEACONS

TWB-63A & TWB-66A



MODEL TWB-63A

SAE CLASS-1 Certified

- Uniform 360 Degree
- Reverse Polarity Protected
- PC lens w/ Smooth Exterior, won't gather Dust
- Shatterproof Polycarbonate lens and base

SPECIFICATIONS

VOLTAGE	12-32 VDC
SURFACE MOUNT	3 Hole Mount
POWER WATTS	18 Watts
LIGHT SOURCE	12 LEDS
FLASH PATTERNS	10 Flash Patterns
WATERPROOF	IP67
WORKING TEMPERATURE	-45F to 150F
SIZE	6"x 6" x 3.25" (L/D/H)

RUGGED, SAE CLASS-1 HIGH INTENSITY 36-LED



MODEL TWB-66A

- Low current draw, high lumens output
- 12 or 24 Volts DC operation
- SAE J845 Class 1 certified
- 4 Different Selectable Flash Patterns:
- Smooth outer lens reduces dust trapping
- Shatterproof Polycarbonate Lens & Base
- Polycarbonate Aluminum-Coated Reflector
- Reverse polarity protected

VOLTAGE	12-32 VDC
SURFACE MOUNT	3 Hole Mount
POWER WATTS	18 Watts
LIGHT SOURCE	12 LEDS
FLASH PATTERNS	10 Flash Patterns
WATERPROOF	IP67 Protection Standard
WORKING TEMPERATURE	-45F to 150F
SIZE	6"x 6"x 7" (L/D/H)

Flash Patterns	FPM (Flash Per Minute)
Double	74
Triple	76
Quad	75
Rotate	143

TRITON 5-YEAR LIMITED WARRANTY

AMBER LED WARNING BEACONS

TWB-65 & TWB-67A

MODEL TWB-65 A/AM



**SAE J845 CLASS-1 and E9 Certified
FIXED / MAGNETIC / POLE MOUNT**

- High Lumens output with low current draw
- Reverse polarity protected
- 8 Selectable flash patterns
- Aluminum base

SPECIFICATIONS

SURFACE MOUNT	3 Screws or Magnets
POWER WATTS	36 Watts
VOLTAGE	10-48 VDC
LIGHT SOURCE	16 LEDS
FLASH PATTERNS	8 Flash Patterns
WATERPROOF	IP67 Protection Standard
WORKING TEMPERATURE	-45F to 150F
SIZE	6"x 6"x 5" (L/D/H)

MODEL TWB-67 A/AM



**SAE J845 CLASS-1 and E9 Certified
FIXED / MAGNETIC / POLE MOUNT**

- High Lumens output with low current draw
- Reverse polarity protected
- 8 Selectable flash patterns
- Aluminum base and top plate

SPECIFICATIONS

SURFACE MOUNT	3 Screws or Magnets
POWER WATTS	36 Watts
VOLTAGE	10-48 VDC
LIGHT SOURCE	16 LEDS
FLASH PATTERNS	8 Flash Patterns
WATERPROOF	IP67 Protection Standard
WORKING TEMPERATURE	-45F to 150F
SIZE	6"x 6"x 7" (L/D/H)

TRITON 5-YEAR LIMITED WARRANTY

CLEAR LED WARNING BEACONS

TWB-63C & TWB-65C

IDEAL FOR SCHOOL BUS APPLICATIONS

**SAE J845 CLASS-1 and E9 Certified
FIXED / MAGNETIC / POLE MOUNT**

MODEL TWB-63C



- High Lumens output with low current draw
- Reverse polarity protected
- 8 Selectable flash patterns
- Aluminum base

SPECIFICATIONS

SURFACE MOUNT	3 Screws or Magnets
POWER WATTS	36 Watts
VOLTAGE	12-24 VDC
LIGHT SOURCE	16 LEDS
FLASH PATTERNS	8 Flash Patterns
WATERPROOF	IP66 Protection Standard
WORKING TEMPERATURE	-45F to 150F
SIZE	5"x5"x4" (L/D/H)

MODEL TWB-65C



**SAE J845 CLASS-1 and E9 Certified
FIXED / MAGNETIC / POLE MOUNT**

- High Lumens output with low current draw
- Reverse polarity protected
- 8 Selectable flash patterns
- Aluminum base

SPECIFICATIONS

SURFACE MOUNT	3 Screws or Magnets
POWER WATTS	36 Watts
VOLTAGE	10-48 VDC
LIGHT SOURCE	20 LEDS
FLASH PATTERNS	8 Flash Patterns
WATERPROOF	IP66 Protection Standard
WORKING TEMPERATURE	-45F to 150F
SIZE	6"x 6"x 5" (L/D/H)

TRITON 5-YEAR LIMITED WARRANTY

CLEAR LED WARNING BEACONS

TWB-55, TWB-65

IDEAL FOR SCHOOL BUS APPLICATIONS

MODEL TWB-55AC/AG/ACM



SAE J845 CLASS-1 and E9 Certified
FIXED / MAGNETIC / POLE MOUNT

- High Lumens output with low current draw
- Reverse polarity protected
- 8 Selectable flash patterns
- PP base

SPECIFICATIONS

SURFACE MOUNT	3 Screws or Magnets
POWER WATTS	17Watts
VOLTAGE	12-24 VDC
LIGHT SOURCE	48 LEDS
FLASH PATTERNS	8 Flash Patterns
WATERPROOF	IP66 Protection Standard
WORKING TEMPERATURE	-45F to 150F
SIZE	5"x5"x4" (L/D/H)

MODEL TWB-65AC/AG



SAE J845 CLASS-1 and E9 Certified
FIXED / MAGNETIC / POLE MOUNT

- High Lumens output with low current draw
- Reverse polarity protected
- 8 Selectable flash patterns
- Aluminum base

SPECIFICATIONS

SURFACE MOUNT	3 Screws or Magnets
POWER WATTS	36 Watts
VOLTAGE	12-48 VDC
LIGHT SOURCE	48LEDS
FLASH PATTERNS	8 Flash Patterns
WATERPROOF	IP66 Protection Standard
WORKING TEMPERATURE	-45F to 150F
SIZE	6"x 6"x 5" (L/D/H)

TRITON 5-YEAR LIMITED WARRANTY

CLASS-1 LED BEACON WITH DIN POWER BRACKET/PLUG TWB-46A-DIN



FEATURES

- SAE CLASS-1 HIGH INTENSITY OUTPUT
- BRONZE CORROSION-PROOF SLEEVE
- FLEXI NECK REDUCES IMPACT DAMAGE
- INTERNAL DIN CONNECTOR

DIN POWER MOUNTING BRACKET

- MODEL TWB-46-BKT (HORIZONTAL TYPE)
- MODEL TWB-46-BKL (VERTICAL TYPE)
- ORDER BRACKET SEPARATELY



TWB-46-BKL



TWB-46-BKT

TRITON 5-YEAR LIMITED WARRANTY

WARNING BEACONS AMBER LED

TWB-58A & TRF-65AM

MODEL TWB-58A-DIN

SAE CLASS-2 and E9 Certified

- DIN Pole mount
- 3 Flash / 4 Rotating patterns
- Reverse polarity protected
- Shatterproof Polycarbonate lens and base

SPECIFICATIONS

VOLTAGE	12-24 VCD
LIGHT SOURCE	10 LEDS
POWER WATTS	28 Watts
FLASH PATTERNS	3 Flash / 4 Rotating Patterns
WATERPROOF	IP67
WORKING TEMPERATURE	-22F to 150F
SIZE	8"x 5" (Height/Diameter)



MODEL TRF-65AM REMOTE CONTROLLED

SAE CLASS-2 and E9 Certified

- 360 Degree magnetic /Suction mount
- Rechargeable warning beacon
- Reverse polarity protected
- Shatterproof Polycarbonate lens and base

SPECIFICATIONS

LIGHT SOURCE	10 LEDS
POWER WATTS	28 Watts
FLASH PATTERNS	3 Flash / 4 Rotating Patterns
WATERPROOF	IP67
WORKING TEMPERATURE	-22F to 150F
SIZE	6"x 5" (Height/Diameter)



TRITON 3-YEAR LIMITED WARRANTY

MAGNA-FLASH™

TMF-50A

MAGNETIC RECHARGEABLE WARNING STROBE LIGHTS

SAE CLASS-1, RUGGED HIGH INTENSITY STROBE LIGHT

- 360 Degree Magnetic
- Rechargeable Warning Strobe Light
- SAE J845 Class-1 Certified
- Reverse Polarity Protected
- 12 Flash Patterns
- Shatterproof Polycarbonate lens and base

SPECIFICATIONS

MAGNETIC MOUNT	20LB Magnet
POWER WATTS	9 Watts
LIGHT SOURCE	12 LEDS
CHARGER	Cigar Plug and Chager
FLASH PATTERNS	12 Patterns
WATERPROOF	IP67
WORKING TEMPERATURE	-1F to 129F
SIZE	5"x 5"x 3.5"



MAGNA-FLASH™



TMF-55A

SAE CLASS-1 SUCTION MAGNA MOUNT

- 360 Degree Magnetic
- Rechargeable Warning Strobe Light
- SAE J845 Class-1 Certified
- Reverse Polarity Protected
- 2 (SAE standards) Flash Patterns
- Shatterproof Polycarbonate lens and base

SPECIFICATIONS

MAGNETIC MOUNT	20LB Magnet
POWER WATTS	4 Hours 110%, 6 Hours Duration
LIGHT SOURCE	36 LEDS
CHARGER	Cigar Plug and Chager
FLASH PATTERNS	2 (SAE Standard) Patterns
WATERPROOF	IP66 Protection Standard
WORKING TEMPERATURE	-22F to 122F
SIZE	5.5"x 5.5"x 4"

TRITON 5-YEAR LIMITED WARRANTY



RECHARGEABLE MAGNETIC LED WARNING BEACON

4" x 4" WARNING STROBE KIT

TRITON AMBER TLP-44A2 AND RED TLP-44R2 MAGNETIC, RECHARGEABLE WARNING LAMP SUITABLE FOR AG EQUIPMENT

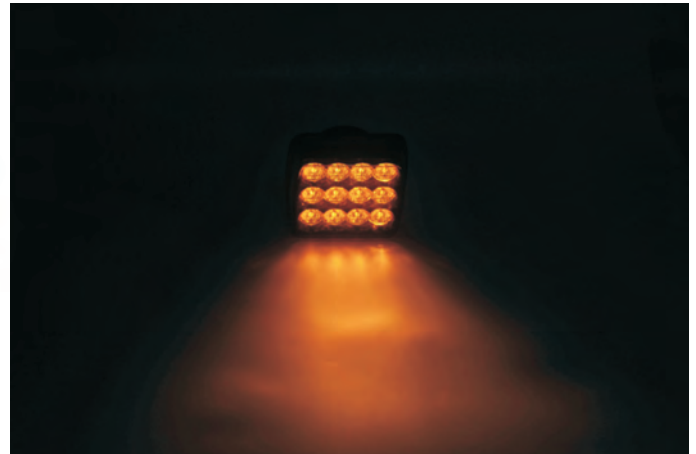

FEATURES

- MAGNETIC RECHARGEABLE
- CARRY CASE (A PAIR)
With dual charge cord
- AMBER/RED COLOR AVAILABLE

SIZE AND COLOR

- 4" X 4" MODEL TLP-44A (AMBER)
- 4" X 4" MODEL TLP-44-R (RED)
- 4" X 4" MODEL TLP-44-A2 (PAIR)
- 4" X 4" MODEL TLP-44-R2 (PAIR)



CARRY CASE (A PAIR) - TLP-44A2 or TLP-44R2



- 4" X 4" MODEL TLP-44R SINGLE
- 4" X 4" MODEL TLP-44A SINGLE

TRITON 3-YEAR LIMITED WARRANTY

LOW-PROFILE MINI STROBE-BARS TMB-107 AND TMB-127 SERIES

HIGH INTENSITY SAE CLASS-1
SLEEK DESIGN SUITS SMALLER VEHICLE APPLICATIONS



Size: 10"x 7" x 2.5" (L/W/H)

RUGGED, SAE CLASS-1 **360 DEGREES HIGH INTENSITY**

- 40 High intensity LEDs
- Low current draw, high lumens output
- 10 to 30 Volts DC operation
- SAE J845 Class 1 certified (solid color)
- 20 Selectable flash patterns
- Last flash pattern memory
- ECE R65 & ECE10 approved
- Shatterproof polycarbonate lens
- ABS cover
- Polycarbonate aluminum-coated reflector
- 8ft Power cord

AMBER: 
FIXED MOUNT MODEL: TMB107A
MAG MOUNT MODEL: TMB107AM

AMBER/CLEAR: 
FIXED MOUNT MODEL: TMB1007AC
MAG-MOUNTMODEL: TMB107ACM

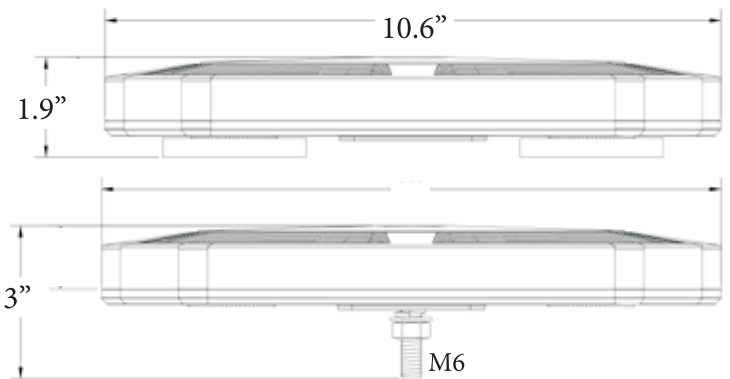

Size: 12"x 7" x 2" (L/W/H)

AMBER: 
MAG MOUNT MODEL: TMB127AM

AMBER/CLEAR: 
MAG-MOUNTMODEL: TMB127ACM

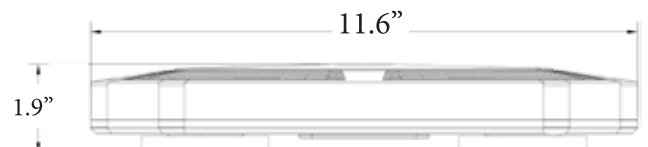

TRITON 3-YEAR LIMITED WARRANTY

LED MINI LIGHT BAR TMB-117 SERIES

SAE CLASS-1 MINI LIGHT BAR

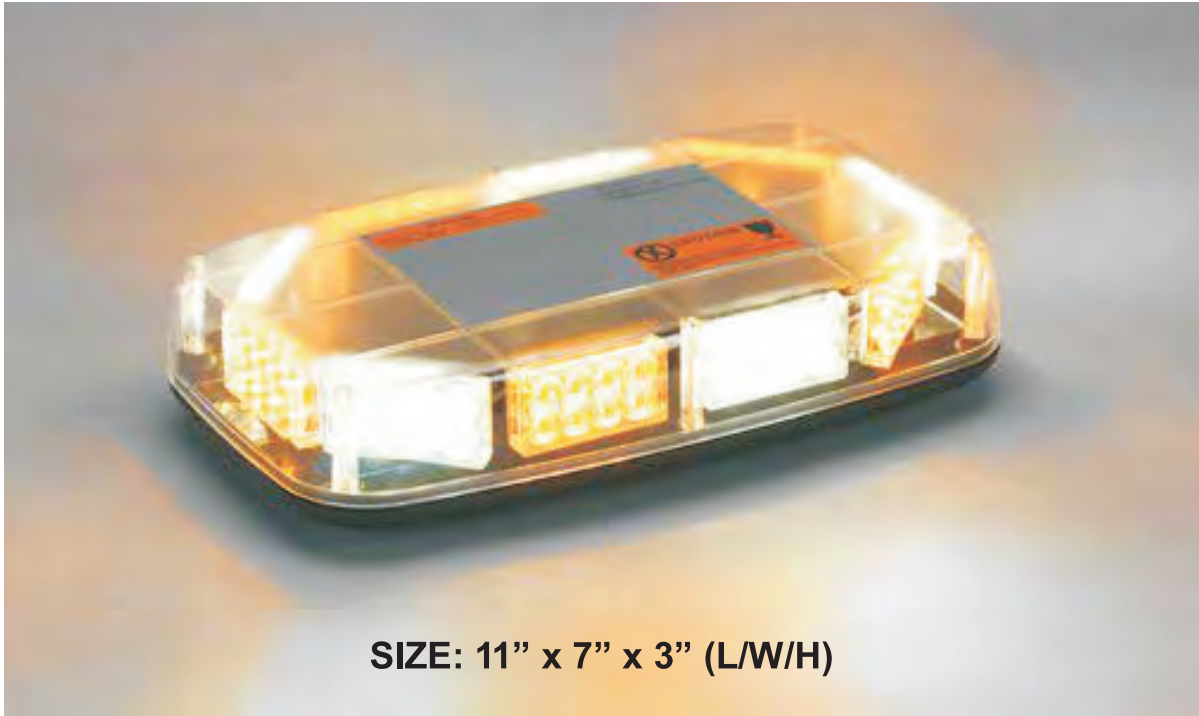

**TBM-3/4
OPTIONAL SIDE
MIRROR MOUNTING
BRACKET**

 **TMB-117AM**

 **TMB-117ACM**

 **TMB-117AGM**

TYPICAL APPLICATIONS:

- UTILITY TRUCKS
- CONSTRUCTION TRUCKS.
- PICKUP TRUCKS.

FEATURES:

- 10 Different, Selectable Flash Patterns.
- 80 COB High-Intensity LED's.
- Power Level: SAE Class-1.
- Voltage: 10 to 32 Volts DC.
- Polycarbonate clear cover.
- Strong base magnets.
- 10ft cord with cigar plug with on/off and flash pattern switches.

TRITON 3-YEAR LIMITED WARRANTY

LED MINI ROTATING STROBE LIGHT BAR TMB-126AM & TLP-126ARC

TLP-126ARC



SIZE: 12" X 6" X 3" (L/W/H)

RECHARGEABLE - MAGNETIC

CERTIFICATION	SAE, ECE, EMC, RIO, CE, ROHS
OPERATING VOLTAGE	12-32 V
LED POWER	30 W
WATERPROOF	IP67
TYPE	BASE MOUNT
FLASH PATTERNS	5 Modes Flash & 5 Modes Rotation
LED COLOR	Amber
LED QUANTITY	84 PCS
OPERATING TEMP.	-40C - 65C
SIZE	12"x 6"x 2" (L/D/H)
CHARGING TIME	4.5 Hours
DISCHARGING TIME	6.5 Hours

**WIRELESS - MAGNETIC - RECHARGEABLE
FULLY REMOTE CONTROLLED
MODEL TLP-126ARC**

TMB-126AM



SIZE: 12" X 6" X 3" (L/W/H)

MAGNETIC ROTATING STROBE BAR

CERTIFICATION	SAE, ECE R65, EMC, R10
OPERATING VOLTAGE	12-32 V
LED POWER	38 W
WATERPROOF	IP67
TYPE	Magnetic Mount
FLASH PATTERNS	5 Modes Flash & 5 Modes Rotation
LED COLOR	Amber
LED QUANTITY	84 PCS
OPERATING TEMP.	-40C - 65C
SIZE	12"x 6"x 2" (L/D/H)
CHARGING TIME	4.5 Hours
DISCHARGING TIME	6.5 Hours

**STROBING AND ROTATING FEATURES
MODEL: TMB-126AM**

TRITON 3-YEAR LIMITED WARRANTY

LED MINI LIGHT BAR

TMB-137 SERIES

SAE CLASS-1 MINI LIGHT BAR



SIZE: 13" X 7" X 3" (L/W/H)

 **TMB-137AM**

 **TMB-137ACM**

 **TMB-137AGM**

TYPICAL APPLICATIONS:

- UTILITY TRUCKS
- CONSTRUCTION TRUCKS.
- PICKUP TRUCKS.

FEATURES:

- 10 Different, Selectable Flash Patterns.
- 48 High-Intensity LED's
- Power Level: SAE Class-1.
- Voltage: 10 to 32 Volts DC.
- Polycarbonate clear cover.
- Strong base magnets.
- 10ft cord with cigar plug with on/off and flash pattern switches.

TRITON 3-YEAR LIMITED WARRANTY

LED MINI LIGHT BAR TMB-159 SERIES



ACTUAL SIZE: 15" x 9" x 3" (W/D/H)

RUGGED, SAE CLASS-1 360 DEGREES HIGH INTENSITY

- Low current draw, high lumens output
- 10 to 30 Volts DC operation
- SAE J845 Class 1 certified
- 10 Selectable flash patterns
- Shatterproof polycarbonate lens and base
- Polycarbonate aluminum-coated reflector
- 8ft Power cord
- Reverse polarity protected
- Four studs or magnet mount

	TMB-159A/AM
	TMB-159R/RM
	TMB-159AC/ACM
	TMB-159RC/RCM
	TMB-159AG/AGM

- AMBER FIXED MOUNT MODEL: TMB-159A**
- AMBER MAGNET MOUNT MODEL: TMB-159AM**
- AMBER/CLEAR FIXED MOUNT MODEL: TMB-159AC**
- AMBER/CLEAR MAGNET MOUNT MODEL: TMB-159ACM**
- RED FIXED/MAGNET MOUNT MODEL: TMB-159R/RM**
- RED/CLEAR FIXED/MAGNET MOUNT MODEL: TMB-159RC/RCM**
- AMBER/GREEN FIXED/MAGNET MOUNT MODEL: TMB-159AGM**

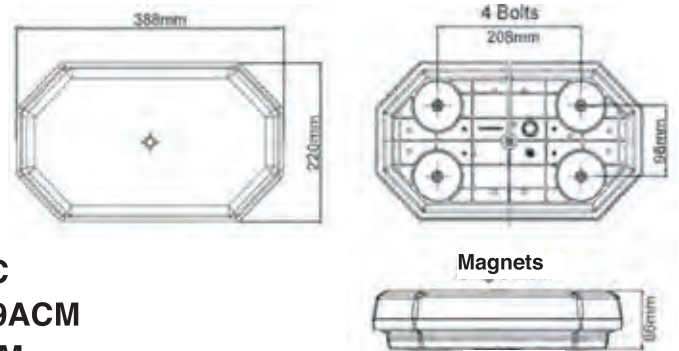

· TRITON 3-YEAR LIMITED WARRANTY

18-INCH LED MINI LIGHT BAR

TMB-1812

18" x 12" SAE CLASS-1

LED MINI LIGHT BAR

ADJUSTABLE SPIDER-LEGS

FOR FLEXIBLE MOUNTING CONFIGURATION.

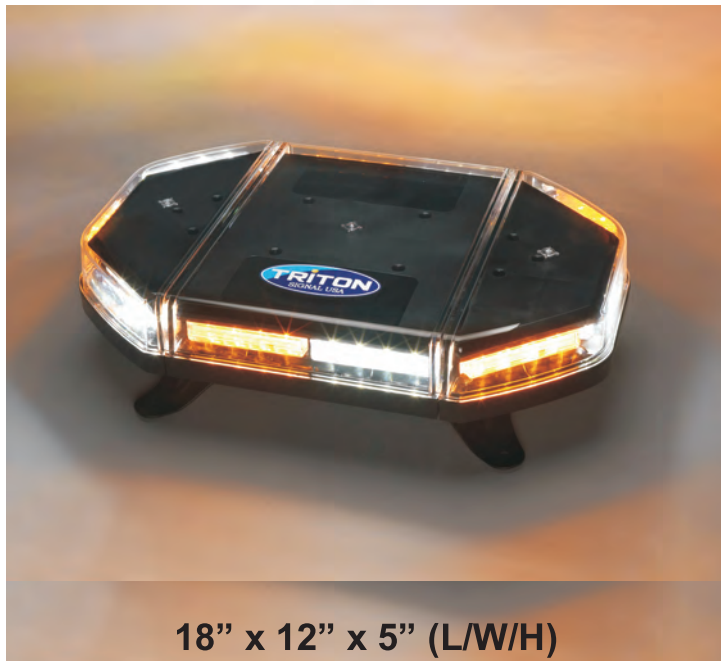

FEATURES:

- 11 Different Selectable Flash Patterns
- 38 COB High-Intensity LED's.
- Power Level: SAE Class-1.
- Voltage: 10 to 32 Volts DC.
- Base and Mounting Feet: Aluminum

TYPICAL APPLICATIONS:

- UTILITY TRUCKS
- CONSTRUCTION TRUCKS.
- PICKUP TRUCKS.

AMBER MODEL: TMB-1812A

AMBER/WHITE MODEL: TMB-1812AC

TRITON 5-YEAR LIMITED WARRANTY

AMBER-SABER TRAFFIC ADVISOR BARS

HIGH-VISIBILITY LOW-PROFILE LED BARS



MODEL TAS-48A (48-INCHES)



REAR STUD SURFACE-MOUNTING



MODEL TAS-40A (40-INCHES)



**INSTALLS ON WINDSHIELD, FRONT OR REAR BUMPER
POWERFUL 3 WATT LEDS IN 18 WATT STROBING MODULES**

SPECIFICATIONS

- 12 Volts D.C. Operation
- Built-in 12 Selectable flash patterns and directional pattern
- Sealed to IP67 Standard
- Flash and director patterns include: "Pass-Left", "Pass-Right", Wig-Wag etc.
- Full-feature controller with 20ft extension cord

TRITON 3 YEAR LIMITED WARRANTY

FULL-SIZED LIGHT BARS



FULL-SIZE 45-INCH LED LIGHT BAR TSB-4512

**ADJUSTABLE SPIDER-LEGS
FOR FLEXIBLE MOUNTING CONFIGURATION.**



45" x 12" x 5" (L/W/H)

TYPICAL APPLICATIONS:

- UTILITY TRUCKS
- CONSTRUCTION TRUCKS.
- PICKUP TRUCKS.

**AMBER MODEL: TSB-4512A
AMBER/WHITE MODEL TSB-4512AC**

FEATURES

- 11 Selectable Flash Patterns
- 164 COB High-Intensity LED's.
- Power Level: SAE Class-1.
- Voltage: 10 to 32 Volts DC.
- Base and Mounting Feet: Aluminum.

Adjustable Spider Legs

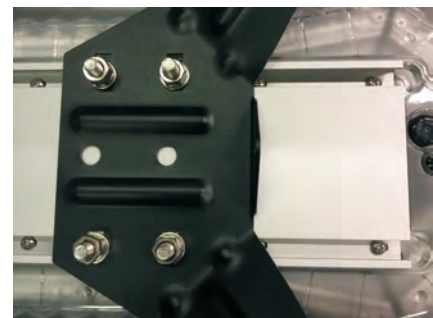

TRITON 5-YEAR LIMITED WARRANTY

SHARK™ STROBE-BAR

FULL-SIZE 54-INCH LOW-PROFILE LED LIGHT BAR TSB-5308



**FULL-SIZE SAE CLASS-1
LED LIGHT BAR**

**AERODYNAMIC SLEEK PROFILE
ADJUSTABLE SPIDER-LEGS
FOR FLEXIBLE MOUNTING
CONFIGURATION.**

TYPICAL APPLICATIONS:

- UTILITY TRUCKS
- CONSTRUCTION TRUCKS.
- PICKUP TRUCKS.

FEATURES:

- 10 Different, Selectable Flash Patterns.
- 136 COB High-Intensity LED's.
- Power Level SAE Class-1.
- Voltage: 10 to 32 Volts DC.
- Base and Mounting Feet: Aluminum.

Adjustable Spider Legs

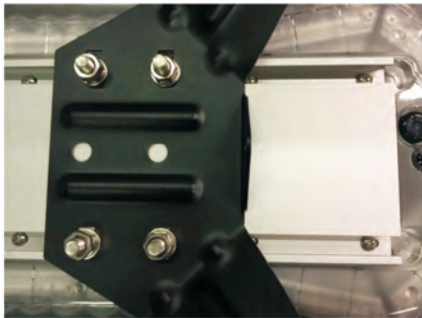

**ADJUSTABLE SPIDER-LEGS
FOR FLEXIBLE MOUNTING CONFIGURATION.**



53" x 8" x 4" (L/W/H)

**AMBER MODEL: TSB-5308A
AMBER/WHITE 50/50 MODEL TMB-5308AC**

TRITON 5-YEAR LIMITED WARRANTY

BULL-SHARK™ ***WRECKER BARS***



FULL-SIZE **LOW-PROFILE** **STROBE BARS**

TSB-5513 / TSB-5513A
TSB-6413 / TSB-6413A

FULL-SIZE 55-INCH & 64 INCH STROBE-LIGHT BARS



**LED TRAFFIC DIRECTOR
WITH STOP/TAIL/TURN
AND WHITE ALLEY AND
TAKE-DOWN LAMPS**



DIMENSIONS:

TSB-5513: 55" x 13" x 4" (L/W/H)

TSB-6413: 64" x 13" x 4" (L/W/H)

FEATURES:

- SAE Class 1
- 45 Selectable Flash Patterns Front & Rear
- COB High-Intensity LEDs
- 10 to 32 Volts
- Mounting Feet and Roof Ties
- Remote controller with display

Adjustable Spider Legs



**AERODYNAMIC SLEEK PROFILE
ADJUSTABLE SPIDER-LEGS
FOR FLEXIBLE MOUNTING
CONFIGURATION**



Triton 5-Year Limited Warranty

D.O.T SIGNAL AND MARKER LAMPS



PRODUCT	LEDS	COLOR	PART #	PRODUCT IMAGES
2" Round Marker Lamp Yellow	4	YELLOW	TML-20Y	
2" Round Marker Lamp Red	4	RED	TML-20R	
2" Round Marker Lamp White	4	WHITE	TML-20W	
1-5/8" x 3/4" Oval Marker Lamp Yellow	2	YELLOW	TML-21Y	
1-5/8" x 3/4" Oval Marker Lamp Red	2	RED	TML-21R	
2.5" Round Marker Lamp Yellow	4	YELLOW	TML-25Y	
2.5" Round Marker Lamp Red	4	RED	TML-25R	
3.75" x 2" Rectangular Marker Lamp Yellow	2	YELLOW	TML-37Y	
3.75" x 2" Rectangular Marker Lamp Red	2	RED	TML-37R	
4" x 2" Rectangular Marker Lamp Yellow	2	YELLOW	TML-40Y	
4" x 2" Rectangular Marker Lamp Red	2	RED	TML-40R	
6" x 2" Rectangular Marker Lamp Yellow	4	YELLOW	TML-60Y	
6" x 2" Rectangular Marker Lamp Red	4	RED	TML-60R	
6" x 3" Oval Marker Lamp Yellow - Chrome Bezel	4	YELLOW	TML-60YS	
6" x 3" Oval Marker Lamp Red - Chrome Bezel	4	RED	TML-60RS	
6" Oval Mid Turn Lamp Yellow	8	YELLOW	TTL-60Y	
Yellow 3/4" Diameter (Mounting) Marker Lamp	1	YELLOW	TML-75Y	
Red 3/4" Diameter (Mounting) Marker Lamp	1	RED	TML-75R	
4" Round Signal Lamp Yellow	18	YELLOW	TSL-4Y	
4" Round Stop/Tail/Turn Lamp Red	18	RED	TSL-4R	
4" Round Back-Up Lamp White	10	WHITE	TSL-4W	
6" Oval Signal Lamp Yellow	20	YELLOW	TSL-6Y	
6" Oval Stop/Tail/Turn Lamp Red	20	RED	TSL-6R	
6" Oval Back-Up Lamp White	10	WHITE	TSL-6W	
2" Round Rubber Grommet		N/A	TGR-20	
2.5" Round Rubber Grommet		N/A	TGR-25	
4" Round Rubber Grommet		N/A	TGR-40	
6" Oval rubber Grommet		N/A	TGR-60	
9-Inch 90 Degree 3-Wire Pigtail with 3-Pin Connector		N/A	TPW-39	
6-Inch 90 degree 2-wire Pigtail with 2-Pin Connector		N/A	TPW-26	
4" Red Round Stop/Tail/Turn Lamp w/Back-Up Lamp	12	RED	TSL-4RW	
6" Red Oval Stop/Tail/Turn Lamp w/Back-Up Lamp	14	RED	TSL-6RW	
16-INCH LED STOP/TAIL/TURN STRIP 12 VOLTS	18	RED	TSL-17R	
16-INCH LED STOP/TAIL/TURN STRIP W/CHROME BEZEL	18	RED	TSL-17R-BEZ	

TRITON 5 YEAR LIMITED WARRANTY

BOX TAIL-LAMP

TSL-76 THREE-STUD MOUNTING STOP-TAIL-TURN & BACK-UP LAMP

MODEL: TSL-76 TSL-76LP (w/LICENSE PLATE LEDS)

- 12 VOLTS
- SAE AND DOT 17 CERTIFIED
- STANDARD THREE-STUD MOUNTING
- SELF-GROUNDING VIA STUDS
- STRONG POLYCARBONATE LENS & BODY
- DIMENSIONS: 6" x 7" x 3" (H/W/D)
- SEALED IP68 DESIGN
- 12 INCH CONNECTION WIRES
- LEFT LAMP INCLUDES LICENSE PLATE LED

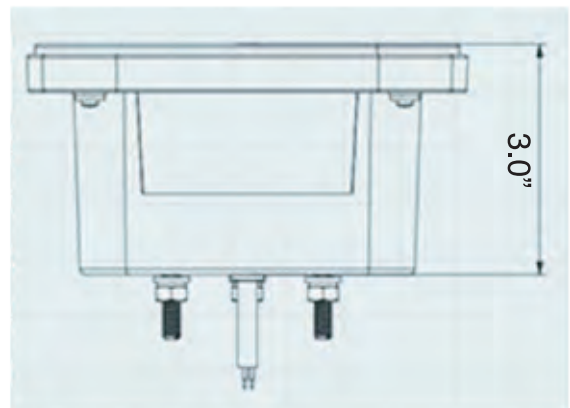
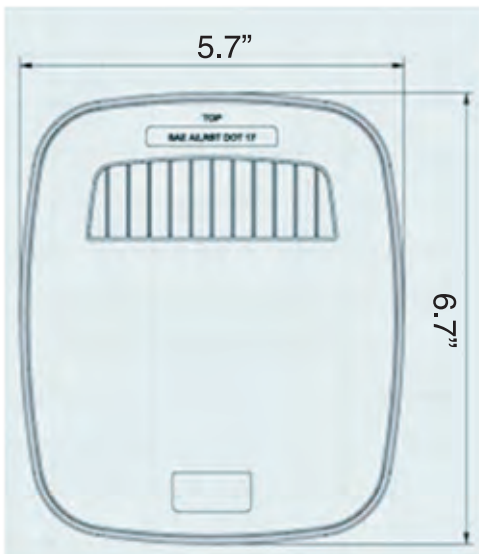

TRITON 3-YEAR LIMITED WARRANTY

AFTERMARKET LED REPLACEMENTS FOR DEERE COMPACT TRACTOR LAMPS MODEL: TSL-2STT

DROP-IN LED REPLACEMENT FOR TRACTOR HALOGEN LAMPS.
INCLUDES OPTIONALLY WIRED BACK-UP LAMPS



REPLACES OLDER HALOGEN
OEM LAMPS SHOWN BELOW

*** SOLD ONLY IN PAIRS ***



FEATURES:

- DOT CONFORMING
- BRIGHTER THAN OEM LAMPS
- HERMETICALLY SEALED TO IP69
- DROP-IN REPLACEMENT
- RUGGED ALUMINUM MOUNT
- POLYCARBONATE LENSES
- USES ORIGINAL MOUNTING BOLTS
- USES ORIGINAL MOUNTING BOLTS
- 3 YEAR WARRANTY
- INCLUDES BACK-UP LAMPS

61

Triton 3-Year Limited Warranty

WIRED & WIRELESS CAMERA SYSTEMS



TCS-50



TCS-70



TCDW-7X



TCS-77



TCS-79HD



TMC-4

TCS-700 4-CAMERA CAPABLE HIGH-DEFINITION CAMERA SYSTEM

SYSTEM COMPONENTS

1. MONITOR: 7-INCH COLOR 4-CHANNEL SPLIT SCREEN CAPABLE
2. CAMERAS: 12 VOLT – WATERPROOF, REAR, FORWARD AND LEFT OR RIGHT SIDE
3. NIGHT VISION (IR)
4. TRIGGER-ABLE CAMERA VIEWS
5. CAMERA CABLES – ONE PER CAMERA



**SPLIT-SCREEN
CONFIGURABLE FOR
1 TO 4 CAMERA VIEWS**



**SUPPORTS 1 TO 4
CAMERAS**



Screen Size	7-inch IPSSuper TFT panel
Aspect Ratio	16:9 image
Video Input	4 channels Split (CVBS/AHD720P/1080P)
Audio Input	4 Channels
Speaker	1 Channel(Options)
Trigger	4 Channels
Resolution	1024 x 3(RGB) X 600
Brightness	520cd/m2
Contrast ratio	700:1
Viewing Angle	H:85 V:85
Storage	128G TF Card
External Dimensions	189*133*57.5mm (W)*(H)*(T)
Operating Voltage	12-36V DC
Power	2.6W(No cameras)
Operation Temperature:	-40°C~+80°C.RH95% Max

TCS-50 & TCS-70 3-CAMERA CAPABLE MONITORING SYSTEMS

TCS-50 (5-INCH) MONITOR SYSTEM
CAMERA & MONITOR SYSTEMS
5-Inch compact color monitor



TCS-50 TYPICAL APPLICATIONS:

- MOBILE AGRICULTURAL MACHINES.
- GAS POWERED FORKLIFTS.
- SKID-STEERS.
- PICKUP TRUCKS.
- COMMERCIAL VANS.

TCS-70 TYPICAL APPLICATIONS:

- SMALL FORKLIFTS.
- SKID-STEERS.
- PICKUP TRUCKS.
- COMMERCIAL VANS.

TCS-70 (7-INCH) MONITOR SYSTEM



TC-6 Camera



FEATURES

- From 1 to 3 cameras
- Works on 12 or 24 volt systems
- Clear sharp image.
- U-shaped mounting bracket resists high vibration.
- Weatherproof camera with night vision.
- Kit Comes with one TC-6 Camera & 64ft camera cable.

3/4" THRU-HOLE BULLET-CAMERA AVAILABLE



PART # TC-3 ACTUAL SIZE SHOWN

Triton 5-Year Limited Warranty.

TCS-78 & TCS-77

SINGLE AND DUAL CAMERA SYSTEMS

TYPICAL APPLICATIONS:

- MOBILE AGRICULTURAL MACHINES.
- GAS POWERED FORKLIFTS.
- COMMERCIAL VANS.
- SMALL FORKLIFTS.
- PICKUP TRUCKS.



TCS-78 SINGLE CAMERA SYSTEM

TCS-77 DUAL CAMERA SYSTEM



TC-7 Standard Camera

- **Wide Field of View**
- **High-Power 12 IR LEDs**
- **Integrated Heater**
- **Integrated Microphone**
- **Camera IP Rating: 69K**
- **Operating Temperature: -40° - +80°C**
- **Minimum Illumination: 0 Lux (IR LEDs ON)**

- **Approval Standards: FCC, CE, E, RoHS, WEEE**
- **Pick-up Element: 1/3" CCD**
- **Illumination Distance: 10m**
- **Viewing Angle (Dia.): 150°**
- **Dimension: 67mm (W) x 40mm (D) x 50mm (H)**



TC-9 90/180/270/360 Configurable

- **High-Quality 1/4" SONY- Super CCD**
- **High Sensitivity & Super-High Resolution**
- **Various Applications (Rear view / Side view / Inside view)**
- **Built-in IR LEDs**
- **Water proof (IP68) Housing**

- **Operating Temperature: -30° - +80°C**
- **Pick-up Element: 1/4" Super HAD CCD**
- **Minimum Illumination: 0 Lux (IR LEDs On)**
- **Illumination Distance: 6m**
- **140° Viewing Angle (Dia):**
- **Dimension: 35mm (W) x 35mm (D) x 46mm (H)**
- **Approval Standards: CE, E, FCC, RoHS**



TC-13 360 Degree Adjustable

- **High Sensitivity & Super-High Resolution**
- **Built-in IR LEDs**
- **Waterproof (IP68) Housing**
- **Low Power Consumption**
- **12V DC Internal Sync**

- **Element Rotates 360 Degrees Compact and Lightweight**
- **Camera IP Rating: 68**
- **Operating Temperature: -30° - +80°C**
- **Approval Standards: FCC, CE, E , RoHS, WEEE**

WATERPROOF IP69K 4 CAMERA SYSTEM MODEL TCS-79HD

HEAVY-DUTY, WATERPROOF CAMERAS AND MONITORING SYSTEM FOR CONSTRUCTION AGRICULTURAL AND MINING MACHINERY



- 7-INCH SPLIT-SCREEN VIEWING
Up to 4 Cameras per System.
- Kit Comes with TC-7HD Camera
- Selectable Split-Screen: Single, Dual, Quad or Single-Screen Views.
- Waterproof – Sealed to IP69K: Cameras and monitor are steam clean and pressure washable.
- Night Vision – 12 high-power IR LEDs illuminate up to 33-Feet.
- 12 or 24 volt systems.
Operating Voltage 10-32 Volts.
- 5 Year Limited Warranty.

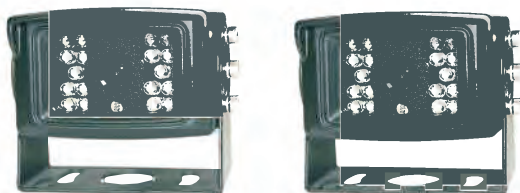
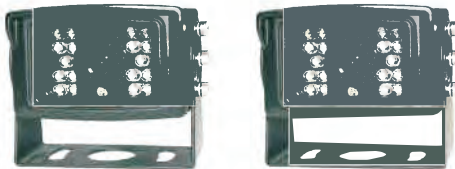

3/4" THRU-HOLE BULLET-CAMERA AVAILABLE



PART # TC-3 ACTUAL SIZE SHOWN

7-INCH DIGITAL WIRELESS 4-CAMERA CAPABLE SYSTEM MODEL TCDW-7X



SPLIT-SCREEN 7-INCH MONITOR

- Up to 4 Cameras per System.
- Kit Comes with TCW-7X Camera.
- Dual, Quad or Single-Screen Monitoring.
- Night Vision Function – IR Distance 33-Feet .
- Recording Function to SD Card (Not Included)
- Operating Voltage 10-32 V.
- Automatic Camera / Monitor Pairing Capability.
- 2.4GHz Wireless Transmission up to 350 feet.
- 1/3" Sony 700TV Lines Cameras.

Triton 5-Year Warranty

MAG-CAM PORTABLE DIGITAL WIRELESS 2-CAMERA CAPABLE SYSTEM MODEL TMS-7

SPLIT-SCREEN 7-INCH MONITOR

- Up to 2 Cameras per System.
- Dual, or Single-Screen Monitoring.
- Night Vision Function – IR Distance 33-Feet .
- Operating Voltage 10-32 V.
- Automatic Camera / Monitor Pairing Capability.
- 2.4GHz Wireless Transmission up to 350 feet.
- 1/3" Sony 700TV Lines Cameras.

Triton 5 Year Limited Warranty.



'MAG-CAM' CAMERA

(Magnetically Attached Wireless Camera)
Rechargeable, Lithium battery powered camera module with high-powered magnet, allows for temporary attachment to the rear of 53ft trailers, for clear rear-view during back-up operation. Patent Pending.

Night Vision Function – IR Distance 33-Feet.
Automatic Camera/Monitor Pairing prevents interference from other wireless systems.
Built-in microphone for dock commands.

Six hours operation per charge.
12 Volt cigarette-plug charger included.
110 Volt power charger included.
2.4GHz Wireless transmission to 1000 feet.

Triton 3 Year Limited Warranty



REAR VIEW MIRROR BACK-UP CAMERA SERIES



TMC-4: 4.3" Reverse triggered monitor with 1 backup camera and cabling.



TMC-7: 7" Reverse triggered monitor with 1 backup camera and cabling.

4.3" MONITOR WITH BUILT-IN DVR



TMC-4VR: 4.3" reverse triggered monitor and forward facing camera built into mirror. Uses micro SD card for continuous recording and digital storage.

FEATURES

- WATERPROOF IP67, CAMERAS.
- EASY INSTALLATION: POWER, GROUND, AND BACK-UP CAMERA TRIGGER WIRE.
- 4mm THICK GLASS
- AUTO DIMMING FOR NIGHT-TIME USE
- 5 YEAR WARRANTY

SYSTEM INCLUDES THE FOLLOWING:

- MIRROR UNIT
- MOUNTING BRACKET
- WINDSHIELD MOUNT PLATE & ADHESIVE
- 30' CABLE FOR REAR CAMERA
- MICRO SD MEMORY CARD.
(TMC-4VR)

Triton 5-Year Warranty

TMC-4DVR2 REAR-VIEW MIRROR WITH DUAL-CAMERA RECORDING FUNCTION

*ACTUAL SIZE MONITOR VIEW SHOWN BELOW



- FULL-SIZE MIRROR WITH 4.3- INCH HIGH-BRIGHTNESS DISPLAY
- TOUCH SCREEN CONTROLS
- AUTOMATIC BACK-UP DISPLAY FOR REVERSING SAFETY
- AUTO-DIMMING MIRROR
- NIGHT-VISION
- ADJUSTABLE-LENS - FRONT 1080 PIXEL RECORDING
- REAR 720 PIXEL RECORDING
- BUILT-IN G-SENSOR AUTOMATICALLY SAVES FILES IF TRIGGERED BY AN IMPACT TO THE VEHICLE
- LOOP-RECORDING FUNCTION
- PARKING MODE FUNCTION TRIGGERS RECORDING OF ANY IMPACT TO THE VEHICLE

COMPACT REAR-VIEW CAMERA



SYSTEM INCLUDES WINDSHIELD ATTACHMENT PAD AND ADHESIVE, COMPACT REAR CAMERA AND ALL REQUIRED CABLING. ALSO INCLUDES AN SD CARD FOR RECORDING.

7-INCH MIRROR DUAL-CAMERA SYSTEM TMC-7VR WITH DUAL RECORDING

FEATURES

- WATERPROOF IP67, CAMERAS.
- EASY INSTALLATION: POWER, GROUND, AND BACK-UP CAMERA TRIGGER WIRE.
- 4mm THICK GLASS
- AUTO DIMMING FOR NIGHT-TIME USE



ACTUAL SIZE

- FULL-SIZE MIRROR WITH 7-INCH HIGH-BRIGHTNESS DISPLAY
- TOUCH SCREEN CONTROLS
- AUTOMATIC BACK-UP DISPLAY FOR REVERSING SAFETY
- AUTO-DIMMING MIRROR
- NIGHT-VISION
- ADJUSTABLE-LENS - FRONT 1080 PIXEL RECORDING
- REAR 720 PIXEL RECORDING
- BUILT-IN G-SENSOR AUTOMATICALLY SAVES FILES IF TRIGGERED BY AN IMPACT TO THE VEHICLE
- LOOP-RECORDING FUNCTION
- PARKING MODE FUNCTION TRIGGERS RECORDING OF ANY IMPACT TO THE VEHICLE

COMPACT FRONT
AND REAR VIEW CAMERAS



DUAL SPLIT-SCREEN FEATURE



SYSTEM INCLUDES THE FOLLOWING:

- MIRROR UNIT
- MOUNTING BRACKET
- WINDSHIELD MOUNT PLATE & ADHESIVE
- 30' CABLE FOR REAR CAMERA
- MICRO TF 64GB MEMORY CARD. (TMC-7VR)

TRITON TKC-500 “K-CAM” **COMPACT REAR-VIEW CAMERA SYSTEM** **FOR KUBOTA SKID-STEER MACHINES**

EASY 30-MINUTE INSTALLATION USING EXISTING BOLT HOLES ON THE MACHINE

THE FOLLOWING PARTS ARE INCLUDED IN THIS KIT:



MONITOR AND WINDOW BRACKET



CAMERA



CAMERA CABLE 64FT

30-MINUTE INSTALLATION PROCEDURE ...

- 1. REMOVE THE TWO BOLTS UNDER THE LEFT SIDE WINDOW**
- 2. USING THE LONGER BOLTS SUPPLIED IN THIS KIT, INSTALL THE MONITOR THE MONITOR SHOULD FACE THE OPERATOR'S SEAT**
- 3. PLUG THE MONITOR INTO THE POWER HARNESS. ENSURE THAT THE PLUG IS COMPLETELY INSERTED.**



**POSITIONS OF THE TWO
BOLTS UNDER THE
OPERATOR'S LEFT SIDE
WINDOW**

- 4. FOLLOW THE WIRING INSTRUCTIONS INCLUDED WITH THE MONITOR**

TRAILER RV AND CARGO LIGHTING



TLC-15



TLC-12S



TLC-18S



TLC-22S



TLC-36S



TLC-93B



TLC-133B



TLC-7S

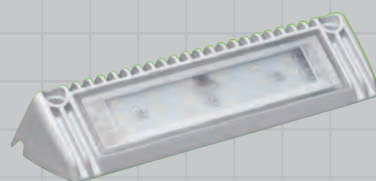

TLC-93W



TLC-133W

LED CARGO-LAMP MODEL TLC-7 & TLC-7S

Ideal for Sleeper-cab, RV, boat and trailer use.

- TLC-7 Light output 800 Lumens, no switch
- TLC-7S Illuminated touch-control with dimming function (Touch and hold to dim)
- Light output 800 Lumens
- 4000-4500K Warm-white LED light
- Waterproof IP67
- Operating voltage 12 Volts
- Wattage: 12 Watts
- Light Output: 800 Lumens



TLC-7 & TLC-7S On



TLC-7S Off with night light

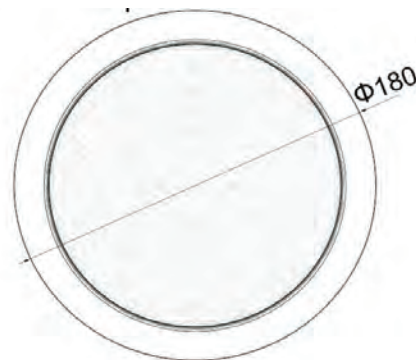

TLC-18S - TLC-24S - TLC-36S SLEEK LOW-PROFILE LED CARGO LAMPS

**HIGH INTENSITY OUTPUT
LESS THAN ONE INCH THICK!**

TYPICAL APPLICATIONS:

- SPRINTER, TRANSIT, & UTILITY VANS
- TRUCK SLEEPER CABS
- BOX TRUCKS
- TRAILERS
- BOATS
- RECREATIONAL VEHICLES



**TLC-18S MODEL (1700 Lumens)
18" x 4" x 1" (L/W/H)**

**TLC-24S MODEL (2000 Lumens)
24" x 2.5" x 1" (L/W/H)**

**TLC-36S MODEL (2800 Lumens)
36" x 2.5" x 1" (L/W/H)**

- Working Voltage: 12 Volts DC.
- Color Temperature: 6000K.
- Diffuser: Acrylic.
- Body: Extruded Aluminum.



BUILT-IN POWER SWITCH



EASY-INSTALL (HARDWARE INCLUDED)

Triton 5-Year Warranty

LED CARGO LAMP MODEL TLC-12S AND TLC-15



WITH ON/OFF SWITCH.

- Ideal for Sleeper-cab, RV, boat and trailer use
- 4000-4500K Warm-white LED light
 - UV-Proof ASA Material
 - Splash-proof IP65 design
 - Operating voltage 12-24 Volts
 - Wattage: 2.75 Watts
 - Light Output 350 Lumens

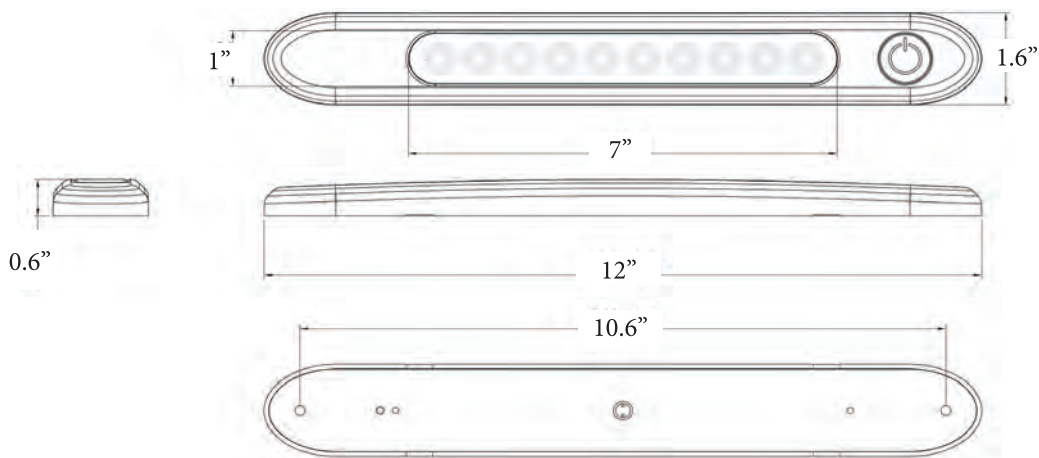

NO ON/OFF SWITCH.
60 DEGREE ANGLED UNIT

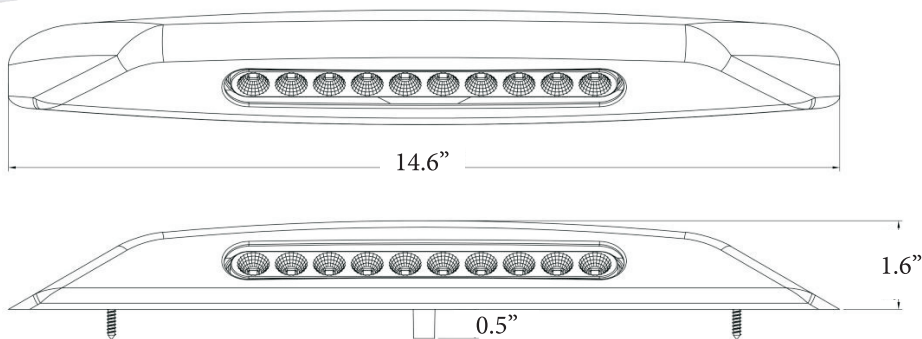

RUGGED 60-DEGREE ANGLE ALLOY LED WORK-LAMPS

IDEAL FOR WORK TRUCK, BOX TRUCK, RV OR BOAT
9-INCH & 13-INCH MODELS TLC-93 & TLC-113



TLC-93B

- Dimensions: 9" x 3" x 3" (L/H/D)
- 18 pcs 1W SMD LEDs (18 Watts)
- Cast Aluminum Housing
- Intensity: 1,450 Lumens



TLC-93W

- Dimensions: 9" x 3" x 3" (W/H/D)
- 18 pcs 1W SMD LEDs (18 Watts)
- Cast Aluminum Housing
- Intensity: 1,450 Lumens



TLC-133B

- Dimensions: 13" x 3" x 3" (W/H/D)
- 27 pcs 1W SMD LEDs (27 Watts)
- Cast Aluminum Housing
- Intensity: 2,250 Lumens



TLC-133W

- Dimensions: 13" x 3" x 3" (W/H/D)
- 27 pcs 1W SMD LEDs (27 Watts)
- Cast Aluminum Housing
- Intensity: 2,250 Lumens

All above lamps are 12/24 Volts.

5-Year Warranty

TLR-3 SERIES WHEEL-WELL ROCK-LAMPS

CHOICE OF FIVE COLORS:

- TLR-3R: RED
- TLR-3B: BLUE
- TLR-3G: GREEN
- TLR-3Y: YELLOW
- TLR-3W: WHITE

- 12 VOLTS OPERATION
- FLAT AND ANGLED RUBBER MOUNTS FOR OPTIMUM LIGHT DISPERSION TO SIDES
- 3 POWERFUL LEDS PER POD
- WATERPROOF
- 10G MECHANICAL SHOCK
- LOW CURRENT CONSUMPTION
- 3 YEAR WARRANTY



WIDE-DISPERSION LIGHT FOOTPRINT



SINGLE-LAMP SET WITH HARDWARE

PORTABLE LED PRODUCTS



TLP-2X



PKT-PEN

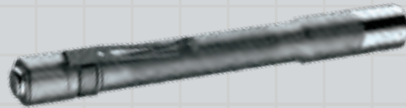

TLP-PEN



TLP-3



TLP-2T



TLP-4



TLP-6



TLP-40MX



TLP-48

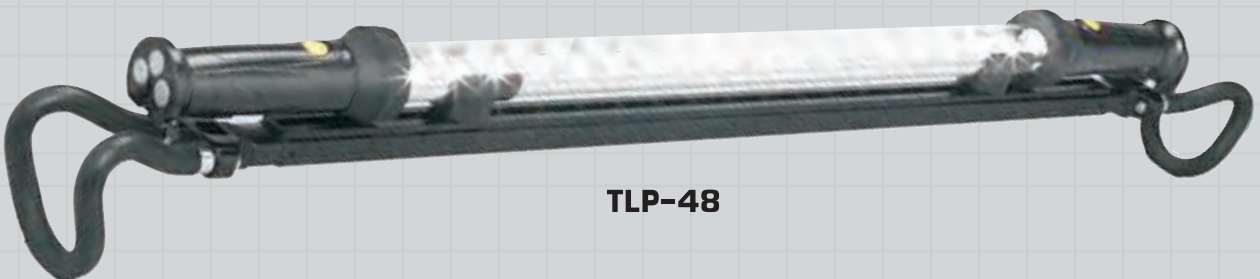



TPC-5



TDL-7



TLP-9

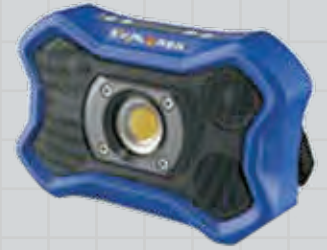

TLS-1000



THL-480



THL-800



TNL-300



TLP-45



TLP-FAN



TLP-44

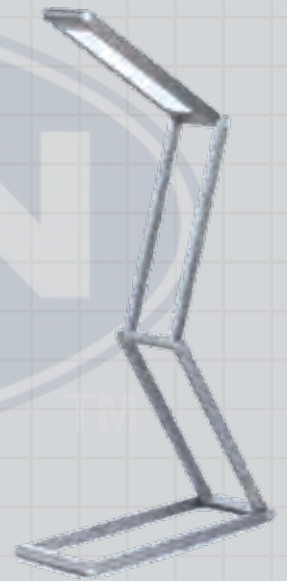

TDL-8



TLK-3



TLK-7



TLK-14



TLP-23



TLP-13



TLP-10



TLP-8000

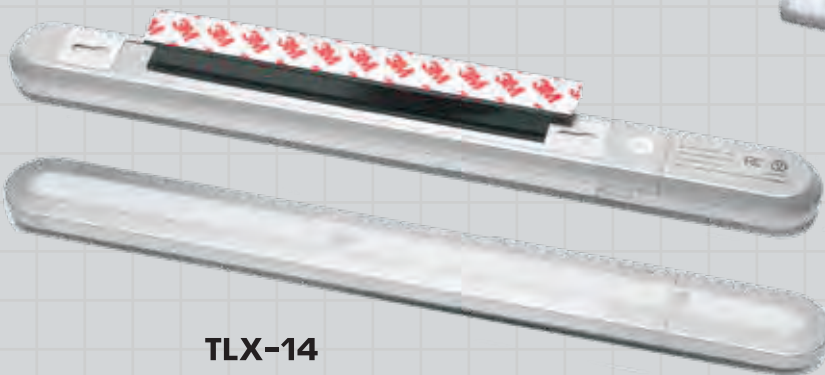

TLX-14



TLX-7

RECHARGEABLE LED KNIFE TLK-3, TLK-7, AND TLK-14

Triton Combo LED Light Knives
Ideal For Emergency Situations, Camping, Hunting, and Everyday Use

TLK-3

- 2" Stainless Steel Blade
- Locking Blade
- 1 LED 5 Lumens
- Micro USB charging port
- 3hr Run Time
- 1hr Quick Charge
- Regular and Phillips Screwdriver
- Bottle Opener and Can Opener
- Soft Touch Switch
- Key Ring Hole
- 3.5" Folded



TLK-7

- 4" Stainless Steel Blade
- Locking Blade
- 1 LED Light 5 Lumens
- Micro USB Charging Port
- 1hr Quick Charge
- 3hr Run Time
- Emergency Glass Breaker
- Carabiner Clip
- 5" Folded



ALL TLK PRODUCTS HAVE A
MICRO USB CHARGING PORT

TLK-14 (Mutli-Tool)

- Stainless Steel Blades
- Locking Blade
- 1 LED 5 Lumens
- Micro USB charging port
- 3hr Run Time
- 1hr Quick Charge
- Key Ring Hole
- Nail File
- Pliers
- Wire Cutting Pliers
- Soft Touch Switch
- Saw
- Fish Scaler
- Bottle Opener & Can Opener
- Regular and Phillips Screwdriver
- 4" Folded



Triton 3-Year Limited Warranty

RUGGED PORTABLE POWER-BANK CHARGER WORK LIGHT

Includes:

- Built-in 1500mAh Polymer Lithium Battery
- Detachable Clamp and Hook On Back Power-Bank
- USB Output, can charge Cell Phones
- 180° Rotating, Foldable, COB Work Light
- Rugged Drop-Proof Case
- Red Strobe Safety Function
- Strong Magnet
- Charge Level Indicator
- One USB Cable

TPC-5



Flood Light: COB—350 Lumens

Charging Time: 3 hours

Runtime: COB 100%-2 Hours

Size: 4.5"x2.6"x1.6"

Drop Resistance: 6ft

Lamp Functions: 100%-50%-Red Light Strobe-OFF

TDL-7 EMERGENCY DYNA-LIGHT™

HAND-CRANKED CHARGER WITH BATTERY BANK, FM/AM RADIO, FLASHLIGHT AND SIREN

Ideal for Emergency Situations, Mobile Jobs, Hunting, and Camping.

Lighting:

The Max. Luminous Flux (0.5W SMD)	>30 Lm
Lighting Time after 1 minute Hand Crank Generated Power (0.5W SMD)	>10 Minutes

Radio:

Radio Time after Fully Charge	≥5 Hours
Radio Time after 1 minute Hand Crank Generated Powered	≥10 Minutes
Output Charging Current	250 ~ 400mA

Siren Alarm:

Siren Alarm Noise	≥ 120dB
Siren Alarm Working Time	≥ 70 Minutes

- Dynamo hand-cranked charger
- Built-in USB cord + Plug for external charging
- 2 Power flashlight
- FM/AM Radio with auto-tuning
- Piercing 120 decibels safety siren
- Size: 6.2" x 2" x 1.5"



Triton 3-Year Limited Warranty

MULTI-FUNCTION FLASHLIGHT RECHARGEABLE MODEL TLP-2X



Light Source: CREE Rechargeable 6W LED(head) + 2W COB(side)

Output: 600 Lumen's (high)

Light Mode: High-Low-COB Strobe

Lighting Time: Approx. 5 Hours

Battery: Lithium 18620 (included)

Size: 6.5" x 1.5"

Weight: 0.5 LBS

With strong magnet on tail-cap



Opening slide cover automatically turns on COB
COB Functions: White/Red/Red Strobing

PKT-PEN (Pocket Pen)

- Single CREE XPG LED
- Zoomable Beam
- Tough Alloy Body
- 2 x AAA Batteries
- 2 (High) to 6 (Low) Hours Run Time
- Output 150 Lumens
- Dimensions: 5" x 0.5" x 0.5" (L/W/D)
- Sealed IP67 Waterproof
- High and Low Output Levels



TLP-PEN

- Single CREE LED
- Zoomable Beam
- Tough Alloy Body
- 750mAH Lithium Battery Rechargeable
- 2 to 4 Hours Run Time
- Output 320 Lumens
- Dimensions: 6.5" x 0.75" x 0.75" (L/W/D)
- Sealed IP67 Waterproof
- High/Low and Strobing Output



TRITON 2-YEAR LIMITED WARRANTY

TWISTER™ TLP-2T

MULTI-FUNCTION MINI FLASHLIGHT

**POWERFUL MINI FLASHLIGHT LITHIUM -
RECHARGEABLE 600 LUMENS 3
FUNCTIONS LOW/HI POWER & STROBE**

- **Function:** High 100%-Low 50%-Strobe-Off
- **Runtime:** 1.5 Hours
- **Charging time:** 3 Hours
- **Size:** 3.6" x 0.8"
- **Drop Resistance:** 3'
- **Swivel Head:** 180°
- **Strong Pocket / Hat Clip**

The TWISTER includes:

- OSRAM P8—600 Lumens
- With Strong Magnetic Base
- Built-in Lithium Battery
- Include One USB Cable



CHICAGO SLUGGER™ MODEL TLP-10

TACTICAL SELF DEFENSE, WINDOW BREAKING FLASHLIGHT

- **RECHARGEABLE USB INPUT/OUTPUT**
- **CREE LED ALUMINUM HOUSING**
- **FUNCTION:** High 100%-Low 50%-Strobe-Off
- **OUTPUT:** 1500 Lumens
- **RUN TIME:** 8-9hours
- **SIZE:** 9.5" x 1.5"



TRITON 2-YEAR LIMITED WARRANTY

PREDATOR™ TLP-333

HUNTING AND TRACKING
UV FLASHLIGHT



ULTRA-VIOLET
BLOOD TRAIL
ILLUMINATOR

CREE
XPG
+ RED LED
+ UV LED
+ COB



6.4" X 1.5"

MULTIPLE FUNCTIONS:

- RED FLASHLIGHT
- ULTRA -VIOLET UV BLOOD-TRAIL LAMP
- WHITE FLASHLIGHT
- RED COB LAMP - WHITE COB LAMP
- RED COB WARNING STROBE LAMP
- RECHARGEABLE 18650 LI-ION BATTERY
- CHARGING TIME: 2-HRS
- WATERPROOF - IMMERSIBLE IN WATER
- HIGH QUALITY CREE XPG LEDS
- 300 LUMENS XPG & 350 LUMENS COB
- STRONG MAGNETIC BASE

UV LIGHT ASSISTS IN TRACKING BLOOD TRAILS

RED LAMPS MAINTAIN NIGHT VISION AND ARE NOT VISIBLE TO PREY

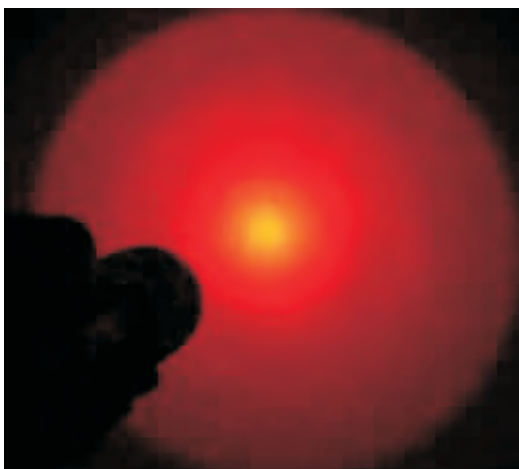

RED COB WORKLAMP AND FLASHLIGHT
MAINTAINS NIGHT VISION FOR HUNTERS
AND CAMPERS AND IS NOT VISIBLE TO
VARMINTS, DEER, ELK AND HOGS

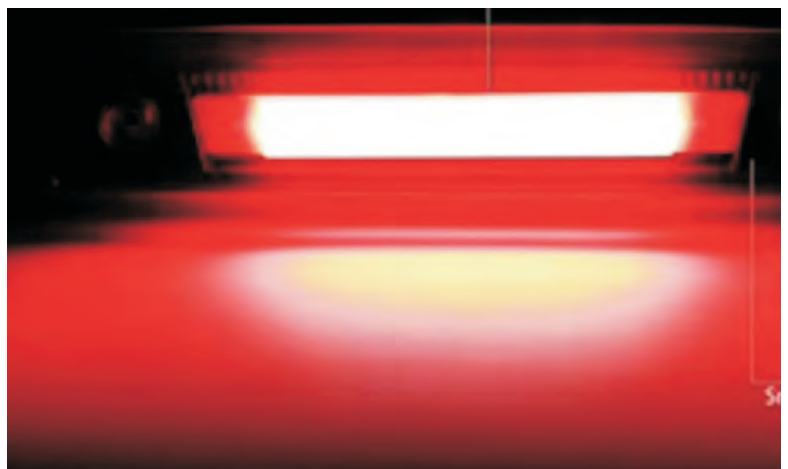

RED COB LANTERN FOR NIGHTTIME
WIDE AREA ILLUMINATION WHILE
MAINTAINING NIGHT VISION

TRITON 2-YEAR LIMITED WARRANTY

STEALTH-TORCH

TLP-555

VARMINT HUNTING FLASHLIGHT

CREE
XPG



Actual Size 6x1.25

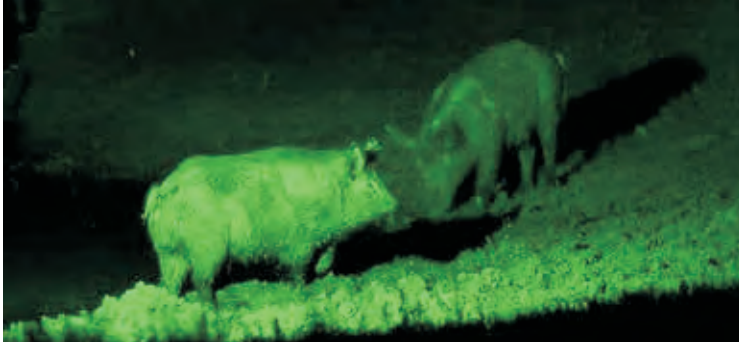

MULTIPLE FUNCTIONS:

- WHITE/RED/BLUE/GREEN
- **RED COB LAMP** - WHITE COB LAMP
- **RED COB WARNING STROBE LAMP**
- RECHARGEABLE 18650 LI-ION BATTERY
- CHARGING TIME: 2-HRS
- WATERPROOF - IMMERSIBLE IN WATER
- HIGH QUALITY CREE XPG LEDS
- 300 LUMENS XPG & 350 LUMENS COB
- STRONG MAGNETIC BASE

RED LAMPS MAINTAIN NIGHT VISION AND ARE NOT VISIBLE TO PREY



RED COB WORKLAMP AND FLASHLIGHT MAINTAINS NIGHT VISION FOR HUNTERS AND CAMPERS AND IS NOT VISIBLE TO VARMINTS, DEER, ELK AND HOGS



RED COB LANTERN FOR NIGHTTIME WIDE AREA ILLUMINATION WHILE MAINTAINING NIGHT VISION

TRITON 2-YEAR LIMITED WARRANTY

MOON SHOT™ MODEL TLP-8000



8000 LUMENS SUPER-POWER RECHARGEABLE FLASHLIGHT



- COB LED
- Tough Alloy Body
- 7.4V 5000mAH Lithium Battery Rechargeable
- 1.5 to 3.5 Hours Run Time
- Output 8000 Lumens
- Dimensions: 11" x 2.5" x 2.5" (L/W/D)
- Sealed IPX4 Waterproof

TRITON 2-YEAR LIMITED WARRANTY

BLACK WIDOW PULSAR™ MODEL TLP-10,000



10,000 LUMENS
SUPER-POWER RECHARGEABLE FLASHLIGHT



- COB LED
- Tough Alloy Body
- 7.4V 5000mAH Lithium Battery Rechargeable
- 1.5 to 3.5 Hours Run Time
- Output 10,000 Lumens
- Dimensions: 12" x 2.25" x 2.25" (L/W/D)
- Sealed IPX4 Waterproof

TRITON 2-YEAR LIMITED WARRANTY

RECHARGEABLE SILICONE LED HEADBAND MODELS THB-450 AND THB-600

THB-450 (450 Lumens) WHITE

- High efficiency 450 Lumens COB COOL-WHITE
- Run time 2.5 to 6 hours (high vs low)
- USB Rechargeable (2.5 hours full charge)
- Type-C USB cord included
- Motion sensor on/off feature
- Soft silicone headband
- Weatherproof and drop resistant



TOUCHLESS WAVE SENSOR
TURNS LAMP ON AND OFF

THB-600 (600 Lumens) MULTI-COLOR

- High efficiency 600 Lumens COB three color output (COOL-WHITE/WARM/RED)
- Run time 2.5 to 6 hours (high vs low)
- USB Rechargeable (2.5 hours full charge)
- Type-C USB cord included
- Motion sensor on/off feature
- Weatherproof and drop resistant

QUAD BEAM RED/WHITE/WARM-
WHITE FLOOD AND SIDE SPOTLIGHT



TOUCH-LESS WAVE SENSOR
TURNS LAMP ON AND OFF

RED COLOR LIGHT MAINTAINS NIGHT VISION
FOR OUDOOR ACTIVITIES - HUNTING, CAMPING

BRIGHT WHITE

WARM WHITE

RED

SPOTLIGHT



TRITON 2-YEAR LIMITED WARRANTY

“HUGGER” Neck Work Light MODEL TNL-300



ON-OFF Switch

SPECIFICATIONS

LIGHT SOURCE	SMD LED
BATTERY	2000mAH Rechargeable
VOLTAGE	3.7 Volts
RUN TIME	2 (Dual) to 4(Single) Hours
OUTPUT	300 Lumens
WATERPROOF	IP67 Protection Standard
WORKING TEMPERATURE	-45F to 150F
SIZE	7”x 5.7”x 1.8” (L/D/H)

BLUETOOTH SPEAKER WORK LIGHT MODEL TLS-1000

SPECIFICATIONS

LIGHT SOURCE	10W COB LED
BATTERY	2000mAH Rechargeable
VOLTAGE	7.4 Volts
RUN TIME	1.7 to 8.2 Hours
OUTPUT	1000 Lumens
WATERPROOF	IP67 Protection Standard
WORKING TEMPERATURE	-45F to 150F
SIZE	7.4”x 5”x 2” (L/W/D)



Power Magnet, 180 Degree Swivel Stand
ON-OFF Switch

TRITON 2-YEAR LIMITED WARRANTY

HANDS FREE RECHARGEABLE LED HEAD-LAMP THL-480/THL-800 RECHARGEABLE MODEL THL-480



Combination Lamp Built-in Sensor ON-OFF
Lamp Removable from Headband
Magnets for attachment to Metal Surfaces

SPECIFICATIONS

LIGHT SOURCE	COB LED (Spot) and (Flood)
BATTERY	2200mAH Rechargeable
VOLTAGE	7.3
RUN TIME	1.7 to 8.2 Hours
OUTPUT	800 Lumens
WATERPROOF	IP67 Protection Standard
WORKING TEMPERATURE	-45F to 150F
SIZE	3.2"x 1.6"x 2" (L/W/D)

RECHARGEABLE MODEL THL-800

Combination Lamp Built-in Sensor ON-OFF
Lamp Removable from Headband
Magnets for attachment to Metal Surfaces



SPECIFICATIONS

LIGHT SOURCE	COB LED (Spot) and (Flood)
BATTERY	2200mAH Rechargeable
VOLTAGE	7.3
RUN TIME	1.7 to 8.2 Hours
OUTPUT	800 Lumens
WATERPROOF	IP67 Protection Standard
WORKING TEMPERATURE	-45F to 150F
SIZE	3.2"x 1.6"x 2" (L/W/D)

RECHARGEABLE LED HAT BRIM LAMP MODEL TLP-9

This product is ideal for:

- Any Outdoor Low-light Work
- Under Vehicle Work
- Fishing and Hunting
- Camping
- Hiking



SPECIFICATIONS

Material	Polyamide
Lamp Type	COB LED
Battery	Internal
Run Time	2 HR / 3 HR
Folded Size	3.3" x 2.3" x 1"
Output Power	100 Lumens
Product's Weight	0.15 lb.
Switching	High>Low>Off

CHUCK-LAMP™ “Chuck it in yer truck”

MODEL TLP-4



IMAGE IS A QUARTER SIZE OF PRODUCT
ACTUAL SIZE: 5" x 4" x 4" (H/W/D)

RUGGED, LITHIUM-POWERED PORTABLE, RECHARGEABLE 3-HOUR WORKLAMP.

Featuring a high intensity 600 lumens flood beam with three operating modes (100% intensity, 30% intensity and an attention-demanding warning flashing mode).

The long-life, lithium rechargeable battery allows the work-lamp to be operated for 3 hours per charge. A cigarette lighter socket and USB charging lead are included.

FOLDS DOWN AND STOWS NEATLY

TOTE-LAMP™ MODEL TLP-6

RUGGED, LITHIUM-POWERED PORTABLE, RECHARGEABLE WORKLAMP WITH POWERFUL MAGNETIC BASE

Featuring a high intensity 1260 lumen Flood beam with three operating modes (100% intensity, 30% intensity and an attention-demanding S.O.S pulsing mode).

The long-life, lithium rechargeable battery allows the work-lamp to be operated for 3 hours per charge. A cigarette lighter socket, USB charging lead and an AC adapter are included.

NEODYMIUM SUPER-MAGNETS



IMAGE IS A QUARTER SIZE OF PRODUCT
ACTUAL SIZE: 7" x 6" x 4" (H/W/D)

Triton 3-Year Limited Warranty

RECHARGEABLE TLP-FAN



- 250 lumens light with 4000 MAH Power Bank
- Lantern Model: High 100%-Mid 50%-Low 20%
- Fan Model: Smooth-Soft-Strong
- Mini Fan+LED Lamp+Flashlight+Power Bank
- Suitable Indoor & Outdoor, Camping

TLP-45 ERADICATOR™ MOSQUITO KILLER LED PORTABLE LAMP



USB & Micro
USB Port

Folding Hanger

Sealed ON/OFF
Switch

Recharges
Phones

Size: 4" x 5" W / H

Weight: 389g

1. Lantern (150 Lumens)

2. Mosquito Killer

3. Lighting Mode: 100% Light 50% Light- Flashing-Off

4. Power Bank for phone charging

5. Cleaning Brush

Mosquito Killer:

Ultraviolet LED UV Wave	6X 0.06W
Length	360-400 nm
Working Time After Fully Charge	> 30 hours
Grid Voltage	> 500V

Others

Specification of Built-in Battery	3.7V, 2000mAh Polymer Li Battery
Input Voltage/Current	5V / 1A
Fully Charge Time via USB Input Cable	Approx. 4 Hours
Lantern LED	5730 SMD, 7500-8000K
Ultraviolet LED	0.06W, Φ 5mm

RECHARGEABLE LED PRODUCTS



Model TLP-13 360 Degree Rotation Folding Lamp

- 390 lumens light with strong magnet cap
- Rechargeable with built-in Li-ion battery
- High-Low-Flashlight beam function
- Runtime: COB 100%-4.5 Hours / 30%- 12 hours
- Suitable Tool box, any metal surface equipment

Model TLP-23 Magnetic Flexible lamp



- 400 lumens light with strong magnet cap
- Rechargeable with built-in Li-ion battery
- Function: High-Low-Off
- Runtime: High-4.5 Hours / Low-12 hours
- Tool box, any metal surface equipments

LED UTILITY LAMP TLP-11

RECHARGEABLE, 950 LUMENS, FLEXI-NECK,

UTILITY-LAMP WITH MAGNETIC BASE AND HANGER HOOK

BRIGHT 950 LUMENS
MULTI-USE FLEXI-LAMP

FUNCTIONS AND RUN TIME
HIGH: 950 LUMENS 5 HOURS
MED: 500 LUMENS 8 HOURS
LOW: 500 LUMENS 8 HOURS

HANGER HOOK

BRIGHT
950
LUMENS



ABS + TPE



10 W SMD



950 Lumens



2pcs 2200mAh 18650
Li-ion battery (included)



STRONG MAGNETIC BASE

TLX-7 MOTION SENSING RECHARGEABLE LED STRIP-LAMP

EASY TO INSTALL IN CLOSETS, SAFES, DRAWERS, TRUNKS, STAIRWELLS ETC., USING SUPPLIED ADHESIVE MAGNETIC STRIP.

COMPACT SIZE: 7.5" x 1.2" x 0.5" (L/H/D) WITH BRIGHT LIGHT

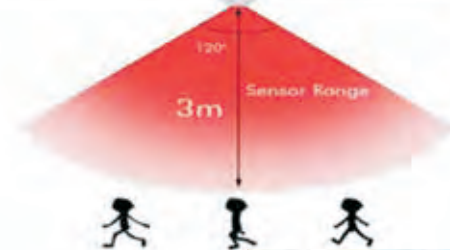
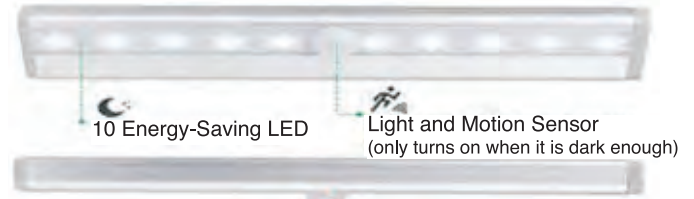

**EASY INSTALLATION
PEEL AND STICK MAGNET STRIP**



RECHARGEABLE LED DESK LAMP MODEL TDL-8

Foldable LED Desk Lamp, USB Rechargeable Portable and Multi-Functional for Reading, Studying, Camping, Home, Bedroom, Car, Plane and Office
Ultra thin Aluminum Alloy Material with the reinforced shaft

- SIZE:** 8.1 x 2.9 x 1.7 Inches
- WEIGHT:** 13.6 Ounces
- TOUCH SWITCH:** High>Low>Off
- POWER CONSUMPTION:** 3 Watts
- INPUT:** 5V/500mAh
- FOLDABLE:** 4 Piece 360° Rotation
- RUN TIME:** 3-4 Hours
- USB CHARGE TIME:** 1-2 Hours



Triton 3-Year Limited Warranty

RECHARGEABLE SENSOR LAMP

14-Inch Rechargeable Sensor Lamp Three Function Auto-on-Off MODEL TLX-14

**EASY TO INSTALL IN TOOL BOX, CLOSETS,
BASEMENT STAIRWELL, USING SUPPLIED MAGNETIC STRIP**



PRODUCT DETAILS

- Wattage: 2.9W
- Length: 14" x 1.5" x 1"
- Color temperature range: White light 5000K
- USB cable, Self-adhesive magnetic strip, 3M adhesive, or alternative fixing screws



LAMP FEATURES:

- 200mA high-capacity rechargeable lithium battery, energy saving with environmental protection, no external power supply required.
- The light is controlled by a microcomputer chip, which is stable and reliable.
- Micro USB charging interface design, strong versatile, fast charging.
- Three function Auto-On-Off



TLP-48 RECHARGEABLE GRAPPLER-LAMP™

Ideally suited to under-hood and inside car/van work applications

**ALLOY CRADLE WITH SPRING-LOADED FOAM-COATED GRIPS
STRETCHES FROM 48 - 77
INCHES TO GRAB HOOD OR
ROOF LEDGES**



- Plug-in 110 Volt Charger
- 36 COB LEDs
- Dual Power Levels: 500 & 1000 Lumens

**48" x 4" x 7" (L/W/H) In Cradle
POWER SWITCHES BOTH ENDS
FOR EASY-REACH ON/OFF**

- Cradle: Extruded Aluminum
- Charging Time: 6 Hours
- Run Time 4 Hours (Unplugged)
- Run Continuously (Plugged In)

MODEL TLP-40MX MAGNETIC WORKLAMP

RUGGED - PORTABLE 4,000 LUMENS MAGNETIC WORKLAMP

FEATURES

- FEATURING A RUGGED ALLOY BODY
- STRONG MAGNETIC-BASE
- BUILT-IN POWER SWITCH ON LAMP
- QUALITY SILICONE 20FT COILED CABLE
- POWDER COATED ALLOY BODY
- WATERPROOF AND SHOCKPROOF
- IMPACT-PROOF POLYCARBONATE LENS
- 12 OR 24 VOLTS OPERATION
- FOLDING HANDLE & ROTATING HEAD
- 8 X 5 WATT CREE XP LEDS
- BRIGHT 4,000 LUMENS OUTPUT
- HIGH- INTENSITY 40 WATT FLOOD LAMP



LAMP SIZE: 6" x 4" x 3.5" (W/H/D)

IDEALLY SUITED FOR:

BOAT AND RV
AGRICULTURAL APPLICATIONS
CAMPERS AND HUNTERS

UTILITY TRUCKS
SEMI TRUCK & TRAILER OPERATIONS
EMERGENCY STORM OUTAGES

Triton 3-Year Limited Warranty

TLP-44STT TRAIL-BURNER™

MAGNETIC WIRELESS STOP-TAIL-TURN LAMPS

- RECHARGEABLE TRAILER S/T/T LAMPS
- SEVEN-WAY (FLAT-PINS) TRAILER PLUG WITH BUILT-IN TRANSMITTER
- PLUG INCLUDES REAR FOUR-WAY FLAT TRAILER SOCKET
- STRONG POLYCARBONATE LENSES
- SEALED IP67 DESIGN
- 12 HOUR RUN-TIME LITHIUM BATTERIES
- STRONG SILICONE-COATED MAGNETS
- HINGED NYLON CARRY-CASE
- CIGAR LIGHTER CHARGING CORD WITH DUAL CHARGING FUNCTION



12 Volt Vehicles Only



RECHARGEABLE MAGNETIC LED WARNING BEACON

4" x 4" WARNING STROBE KIT

TRITON AMBER TLP-44A2 AND RED TLP-44R2 MAGNETIC, RECHARGEABLE WARNING LAMP SUITABLE FOR AG EQUIPMENT

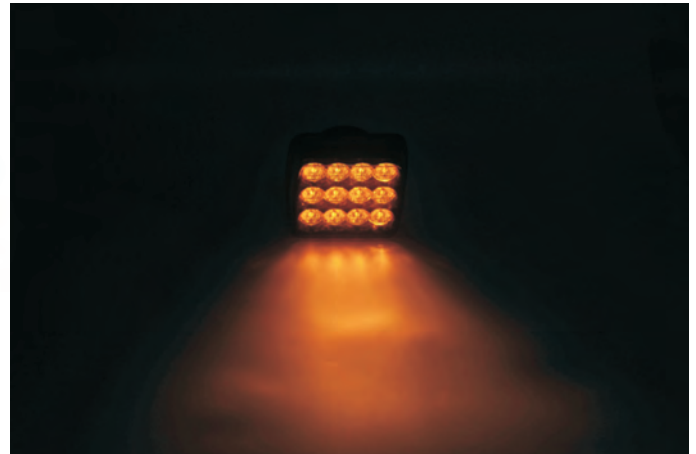

FEATURES

- MAGNETIC RECHARGEABLE
- CARRY CASE (A PAIR)
With dual charge cord
- AMBER/RED COLOR AVAILABLE

SIZE AND COLOR

- 4" X 4" MODEL TLP-44A
- 4" X 4" MODEL TLP-44-R
- 4" X 4" MODEL TLP-44-A2 (PAIR)
- 4" X 4" MODEL TLP-44-R2 (PAIR)



CARRY CASE (A PAIR) - TLP-44A2 or TLP-44R2



- 4" X 4" MODEL TLP-44R SINGLE
- 4" X 4" MODEL TLP-44A SINGLE

TRITON 3-YEAR LIMITED WARRANTY



LED LIGHT STRIPS

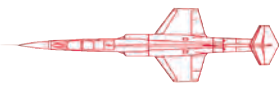

STARFIGHTER™

SUPER INTENSITY LED STRIPS
 PATENT PENDING



TLSF-7 LED STRIP SERIES

- **WHITE**
- **7-Inch x 5/8"**
- **100-LED Strip**
- **12V w/Screws & Adhesive Backed Tape**
- **WHITE: TLSF-7 750 Lumens**
- **AMBER: TLSF-7A 750 Lumens**
- **RED: TLSF-7R 750 Lumens**



Triton 10-Year Limited Warranty

STARFIGHTER™

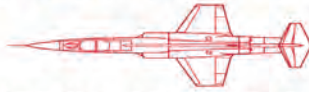

SUPER INTENSITY LED STRIPS

TLSFN-24 & TLSFN-36

Rigid Anodized Aluminum LED Strip

- **WHITE**
- **TLSFN-24: 24" x 1/2"**
- **TLSFN-36: 36" x 1/2"**
- **300/400 LED Strip**
- **12V Immersible w/ Screws & Adhesive Backed Tape**



TYPICAL INSTALLATION IN AN UPFITTED SPRINTER VAN



BEFORE ADDING LED STRIPS



AFTER TLSFN-36 INSTALLATION

TLS-13 & TLS-25

12V Immersible w/
Screws & 3M Adhesive
Backed Tape

TLS-13: 13" x 7/8"

TLS-25: 24" x 7/8"

- TLS-13 : WHITE 750 Lumens**
- TLS-13B : BLUE 750 Lumens**
- TLS-13R : RED 750 Lumens**
- TLS-13A : AMBER 750 Lumens**
- TLS-25 : WHITE 25" 1,500 Lumens**

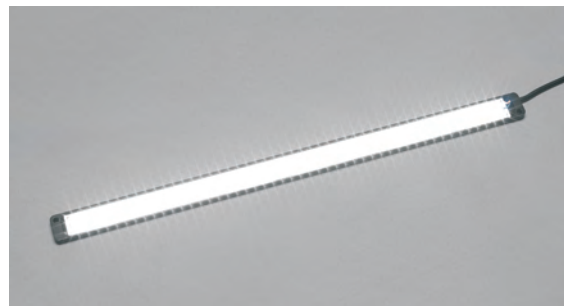

TFS-60, AND TFS-197 LED FLEXI-STRIPS

(60 AND 197 INCH LENGTH STRIPS)

AVAILABLE IN WHITE OR AMBER

Extremely flexible LED strip with 3M adhesive backing and screw clip options. Suitable for exterior and interior placement.

AVAILABLE TYPES

TFS-60: 60 INCHES WHITE OR TFS-60A: AMBER

TFS-197: 197 INCHES (16FT) WHITE OR TFS-197A: AMBER

FEATURES OF TFS-60/TFS-197

- **BEAM ANGLE: 180 Degrees**
- **CONNECTION TYPE: Pigtail**
- **DIMMABLE: Yes**
- **WATERPROOF: IP68**
- **LIGHT OUTPUT: 680 Lumens**
- **WARRANTY: 1 Year**
- **MOUNTING TYPE: 3M Adhesive or Screw Clips**
- **SIZE: 60" x 0.3" / 197" x 0.3"**
- **POWER CONSUMPTION: 18 Watts**
- **OPERATING VOLTAGE: 1.2 Amps**
- **LED's: 346 LEDs**





BACK-UP ALARMS



TB17D-G

- 97 dB
- 12/24v
- Self Grounding w/Stud Terminals
- 3 Year Warranty



TB17D-W

- 97 dB
- 12/24 Volts w/1ft wires
- 3 Year Warranty



TB17C-G

- 102 dB
- 12/24v
- Self Grounding w/Stud Terminals
- 3 Year Warranty



TB17C-W

- 102 dB
- 12/24 Volts w/1ft wires
- 3 Year Warranty



TB19C-WDF

- 102 dB
- Dual Function
- 12/24V w/Wires
- (Back-up & 2-Tone)
- 3 Year Warranty



TB20B-DC

- 107 dB
- 12/24 Volts
- Heavy-Duty w/ Deutsch Connector
- 3 Year Warranty

ALL TRITON HEAVY-DUTY MODELS FEATURE OUR PATENTED PRESSURE PORT SELF CLEANING SYSTEM



TB20B-W

- 107 dB
- 12/24 Volts
- Heavy-Duty w/Wires



TB21A-DCO

- 112 dB
- 12/24 Volts
- Heavy Duty w/Deutsch Connector



TB21A-S

- 112 dB
- 12/24 Volts
- Heavy Duty w/Stud Terminals



TB21A-W

- 112 dB
- 12/24 Volts
- Heavy Duty & 1ft Wires



TB21A-WO

- 112 dB
- 12/24 Volts
- OEM Heavy Duty & 1ft Wires



TB24D-W

- 97 dB
- 12/24 Volts
- 4 inch Grommet Mount Back-up Alarm



All the Above 3- Year Warranty



TB25C-W

- 102 dB
- 12/24 Volts
- 4 inch Grommet Mount Back-up Alarm
- 3 Year Warranty



TB26B-W

- 107 dB
- 12/24 Volts
- Low Cost Durable-Reflex Model
- 3 Year Warranty



TB29H-S

- 82-102 dB
- 12/24 Volts w/Studs
- Auto Adjusting HARK ALARM™
- 3 Year Warranty



TB29H-W

- 82-102 dB
- 12/24 Volts w/Wires
- Auto Adjusting HARK ALARM™
- 3 Year Warranty



TB30H-W

- 82-107 dB
- 12/24 Volts w/Wires
- Auto Adjusting HARK ALARM™
- 3 Year Warranty



TB31H-W

- 87-112 dB
- 12/24 Volts w/Wires
- Auto Adjusting HARK ALARM™
- 3 Year Warranty



TB31H-WO

- 87-112 dB
- 12/24 Volts OEM
- Auto Adjusting HARK ALARM™
- 3 Year Warranty



TB31H-WDCDFO

- 87-112 dB & 112dB Tone
- 12/24 Volts OEM w/Deutsch
- Dual-Function HARK ALARM™
- 3 Year Warranty



TB75B-G

- 107 dB
- 12/24 Volts
- Alarm 3-1/4"
- Mount Bracket w/Stud Connections
- 3 Year Warranty



TB75B-W

- 107 dB
- 12/24 Volts
- Alarm 3-1/4"
- Mount Bracket w/12" Wires
- 3 Year Warranty

CUSTOMER SERVICE

Our responsive customer service staff look forward to assisting you with your product needs



 (877) 874-3744

CONTACT US



TOLL FREE: (877) 874-3744

TECHNICAL ASSISTANCE

Triton's intrepid engineering staff are currently working on warp drive motors for intergalactic cruisers. However, they will be more than happy to break away to respond to your specific technical needs.





TRITON SIGNAL USA
1025 N. Lombard Road
Lombard, IL 60148
www.triton-signal.com
Toll-Free: (877) 874-3744