

TSFM SUPER-NOVA™ THRU-HOLE FLUSH-MOUNT STROBES



- THROUGH-HOLE FLUSH-MOUNT DESIGN
- RUGGED DIECAST ALUMINUM HOUSING
- POLYCARBONATE (PC) LENS
- OPERATING VOLTAGE: 10 TO 32 VOLTS
- SEALED IP67 DESIGN
- HIGH INTENSITY SAE CLASS-1 OUTPUT
- INTEGRATED CONTROL CIRCUITRY
- OPTIONAL 90 DEGREE STEEL BRACKET

TSFM-4 SINGLE AND DUAL COLORS

- TSFM-4C: SINGLE **WHITE**
- TSFM-4A: SINGLE **AMBER**
- TSFM-4AC: DUAL **AMBER/WHITE**
- TSFM-4AG: DUAL **AMBER/GREEN**
- TSFM-4G: SINGLE **GREEN**
- TSFM-4R: SINGLE **RED**
- TSFM-4RB: DUAL **BLUE**
- TSFM-4RB: DUAL **RED/BLUE**

Triton 3 Year Limited Warranty



ACTUAL SIZE
7/8"X1.3" (D/L)



**L-BRACKET AVAILABLE FOR
PURCHASE SEPARATELY AS TSFM-BKT**



MOUNTING GROMMET INCLUDED

CONCEALED LED STROBE SYSTEM

MODEL THS-2



- Small Light-Head for internal mount within composite headlamps, turn-lamps and tail-lamps
- Selectable flash patterns with auto-synchronize features
- Lens design enhances light distribution
- Surface mount bezels (Black and Chrome)
- Base mounts vertically or horizontally
- Available in Amber, White, White/Amber, Amber/Green Or Clear
- Durable, polycarbonate lens for maximum impact resistance

Units = Inches

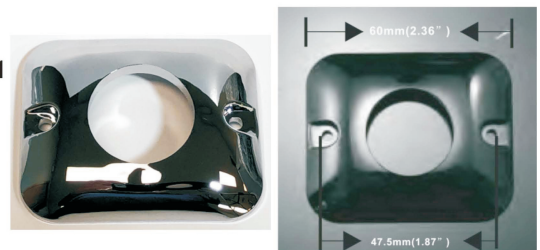
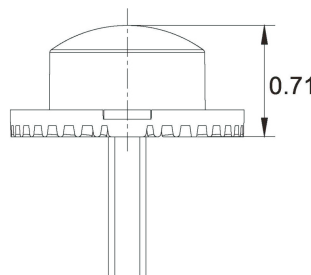
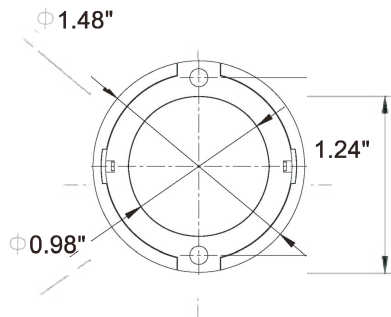

CHROME BEZELS & BLACK BEZELS INCLUDED

Technical Data:

Tech Specs:	
Flash patterns:	14 flash patterns
Mounting:	Headlight, Taillight or Surface Mount with optional Bezels
Input Voltage:	10-32V
Colors choice:	Amber Amber/White
Operations Temperature:	-40°to + 65°C

Triton 5-Year Limited Warranty



TWS "WAFER STROBE" SERIES



TWS-4A (AMBER) TWS-4AC (AMBER/WHITE) TWS-4C (WHITE)

ALL MODELS ARE 0.25" THICK



- INPUT VOLTAGE: 10~33V DC
- 3 WATT LEDS
- SAE CLASS-1
- SHATTERPROOF PC LENS
- WATERPROOF - IP68
- MULTIPLE FLASH PATTERNS



TWS-6A (AMBER) TWS-6AC (AMBER/WHITE) TWS-6AG (AMBER/GREEN)



SINGLE COLOR AND DUAL COLOR 50/50 MODELS



TWS-12 MODEL - AVAILABLE COLORS

- AMBER ONLY: TWS-12A
- AMBER/WHITE (SPLIT): TWS-12AC
- RED/BLUE (SPLIT): TWS-12RB
- AMBER/GREEN (SPLIT): TWS-12AG

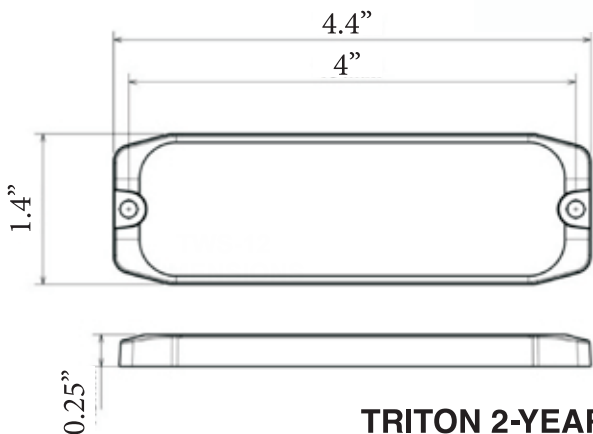

TRITON 2-YEAR LIMITED WARRANTY

SNAKE-EYE™

AMBER GRILL STROBE

TGS-6 SERIES

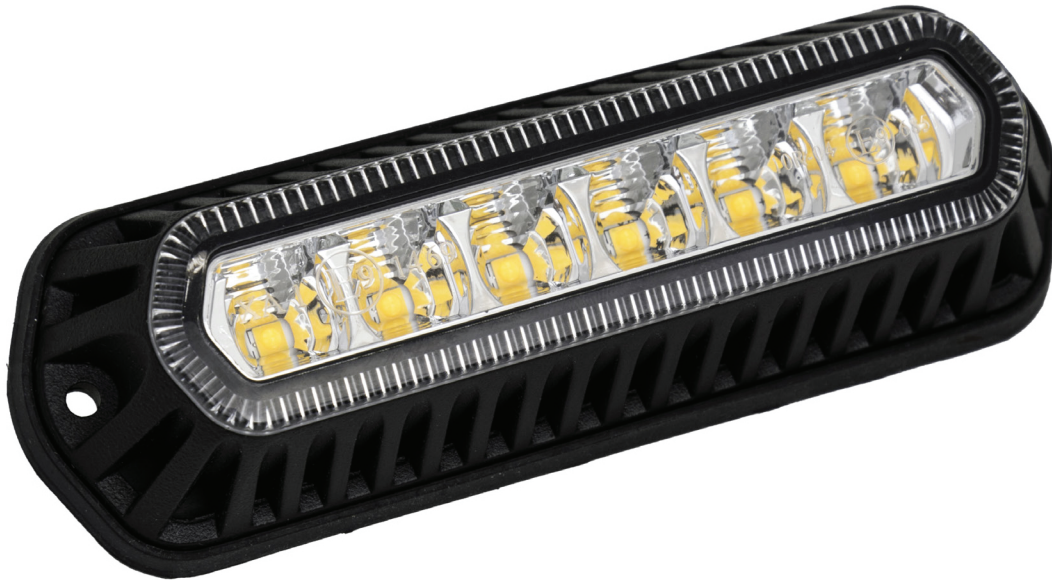

ACTUAL SIZE: 5.5" x 1.4" x 2" (W/D/H)

- **RUGGED, SAE CLASS-1**
- **GRILL-MOUNT HIGH INTENSITY**
- 6 High intensity 3 watt LEDs
- Low current draw, high lumens output
- 10 to 30 Volts DC operation
- SAE J845 Class 1 certified
- 22 Pre-selectable flash patterns
- Last flash pattern memory
- Shatterproof polycarbonate lens
- Polycarbonate aluminum-coated reflector
- Cast aluminum housing
- Two-bolt mounting

MODEL: TGS-6A (Amber)

MODEL: TGS-6C (Clear)

MODEL: TGS-6AC (50/50 Amber/Clear LEDs)

MODEL: TGS-6R (Red)

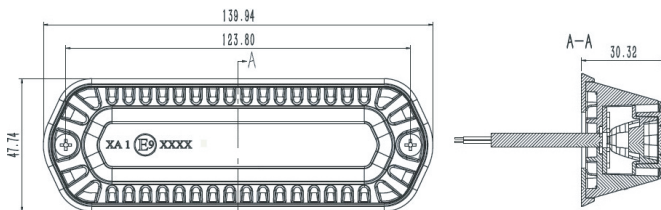
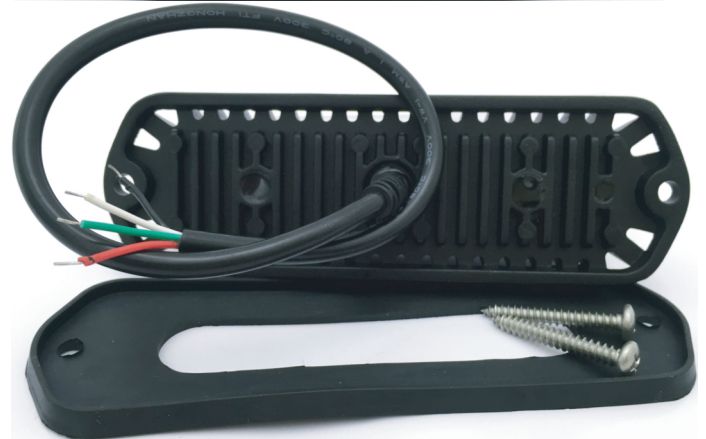

Triton 5-Year Limited Warranty.

SNAKE-EYE™ UNIVERSAL-MOUNT AMBER STROBE TUS-6 SERIES

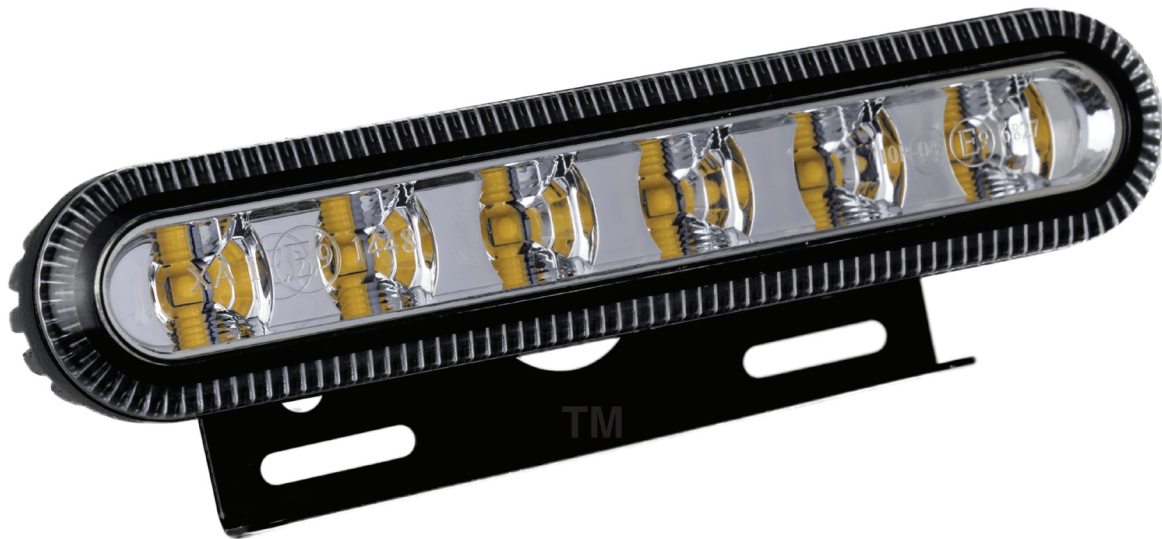

ACTUAL SIZE: 5.5" x 1.4" x 1.2" (W/D/H)

- **RUGGED, SAE CLASS-1**
- **UNIVERSAL HIGH INTENSITY**
- 6 High intensity 3 watt LEDs
- Low current draw, high lumens output
- 10 to 30 Volts DC operation
- SAE J845 Class 1 certified
- 22 Pre-selectable flash patterns
- Last flash pattern memory
- Shatterproof polycarbonate lens
- Polycarbonate aluminum-coated reflector
- Cast aluminum housing
- Universal mount with L-bracket
- Reverse polarity protected

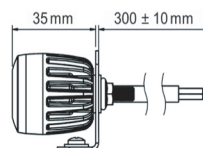
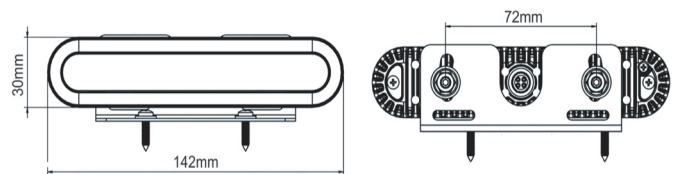

UNIVERSAL TYPE WITH L-BRACKET
MODEL: TUS-6A (Amber)
MODEL: TUS-6C (Clear)
MODEL: TUS-6AC (50/50 Amber/Clear LEDs)
MODEL: TUS-6R (Red)

Triton 5-Year Limited Warranty

SURFACE STROBE TSS-6 SERIES



RUGGED, SAE CLASS-1 HIGH INTENSITY SURFACE STROBES

- Low current draw, high lumens output
- TSS-4, TSS-6 Single Color 15 Selectable flash patterns
- Dual color 8 Selectable flash patterns
- TSS-3, TSS-12 19 Selectable flash patterns
- Last flash pattern memory
- Shatterproof polycarbonate lens
- Polycarbonate aluminum-coated reflector
- Cast aluminum housing
- Universal mount with L-bracket
- Reverse polarity protected

AVAILABLE COLORS:

- TSS-3A: Amber
- TSS-3C: Clear
- TSS-4A: Amber
- TSS-4A/C: Amber/Clear
- TSS-6A: Amber
- TSS-6AC: Amber/Clear
- TSS-6C: Clear
- TSS-6R: Red
- TSS-6B: Blue
- TSS-6AB: Amber/Blue
- TSS-6AG: Amber/Green
- TSS-6BR: Blue/Red
- TSS-6RC: Red/Clear
- TSS-12A: Amber
- TSS-12AC: Amber/Clear
- TSS-12AB: Amber/Blue
- TSS-12AG: Amber/Green

SPECIFICATIONS TSS-3

LIGHT SOURCE	3X3 WATT LEDs
SIZE	2.75" x 1" x 0.4"
WATERPROOF	IP68
WORKING TEMP	-14°F to 149°F
VOLTAGE	10 - 30V
WATTAGE	9 Watts

SPECIFICATIONS TSS-4

LIGHT SOURCE	4X3 WATT LEDs
SIZE	3.74" x 1.18" x 0.51"
WATERPROOF	IP6K9K
WORKING TEMP	-14°F to 149°F
VOLTAGE	10 - 30V
WATTAGE	9 Watts

SPECIFICATIONS TSS-6

LIGHT SOURCE	6X3 WATT LEDs
SIZE	4.79" x 1.18" x 0.51"
WATERPROOF	IP68
WORKING TEMP.	-14°F to 149°F
VOLTAGE	10 - 30V
WATTAGE	12 Watts

SPECIFICATIONS TSS-12

LIGHT SOURCE	12X3 WATT LEDs
SIZE	4.25" x 1.5" x 0.5"
WATERPROOF	IP68
WORKING TEMP.	-14°F to 149°F
VOLTAGE	10 - 30V
WATTAGE	36 Watts

Triton 3-Year Limited Warranty

1-877-874-3744

www.triton-signal.com

TWB-400A & TWB-600A LED FLUSH-MOUNT STROBES

**SAE CLASS-1
GROMMET-MOUNT
STROBE-LIGHT**



SIZE: 4"x 4"x 1" (L/W/H)

TYPICAL APPLICATIONS:

- **UTILITY TRUCKS**
- **CONSTRUCTION TRUCKS**
- **PICKUP TRUCKS**



**AMBER: TWB-600A
AMBER/GREEN: TWB-600AG**



TWB-400A

FEATURES:

- 6 Different, Selectable Flash Patterns.
- Power Level: SAE Class-1.
- Voltage: 10 to 16 Volts DC.
- Base and Mounting Feet: Aluminum.
Available in AMBER or AMBER/GREEN

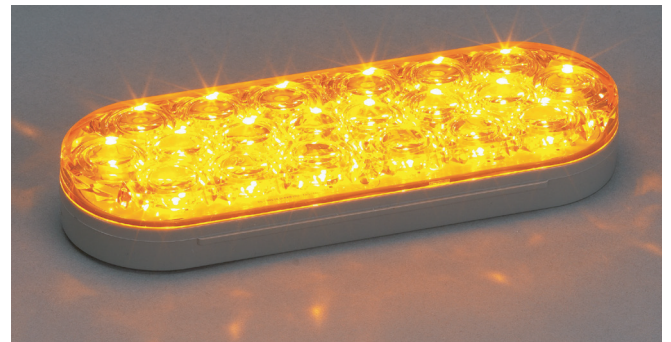

SIZE: 6.5"x 2.25"x 1" (L/W/H)

Triton 5 Year Limited Warranty